

RECOMMENDED PRACTICE
DNV-RP-C201

BUCKLING STRENGTH OF
PLATED STRUCTURES

OCTOBER 2010

DET NORSKE VERITAS

FOREWORD

DET NORSKE VERITAS (DNV) is an autonomous and independent foundation with the objectives of safeguarding life, property and the environment, at sea and onshore. DNV undertakes classification, certification, and other verification and consultancy services relating to quality of ships, offshore units and installations, and onshore industries worldwide, and carries out research in relation to these functions.

DNV service documents consist of amongst other the following types of documents:

- *Service Specifications*. Procedural requirements.
- *Standards*. Technical requirements.
- *Recommended Practices*. Guidance.

The Standards and Recommended Practices are offered within the following areas:

- A) Qualification, Quality and Safety Methodology
- B) Materials Technology
- C) Structures
- D) Systems
- E) Special Facilities
- F) Pipelines and Risers
- G) Asset Operation
- H) Marine Operations
- J) Cleaner Energy
- O) Subsea Systems

The electronic pdf version of this document found through <http://www.dnv.com> is the officially binding version

© Det Norske Veritas

Any comments may be sent by e-mail to rules@dnv.com

For subscription orders or information about subscription terms, please use distribution@dnv.com

Computer Typesetting (Adobe Frame Maker) by Det Norske Veritas

If any person suffers loss or damage which is proved to have been caused by any negligent act or omission of Det Norske Veritas, then Det Norske Veritas shall pay compensation to such person for his proved direct loss or damage. However, the compensation shall not exceed an amount equal to ten times the fee charged for the service in question, provided that the maximum compensation shall never exceed USD 2 million.

In this provision "Det Norske Veritas" shall mean the Foundation Det Norske Veritas as well as all its subsidiaries, directors, officers, employees, agents and any other acting on behalf of Det Norske Veritas.

CHANGES

- **General**

As of October 2010 all DNV service documents are primarily published electronically.

In order to ensure a practical transition from the “print” scheme to the “electronic” scheme, all documents having incorporated amendments and corrections more recent than the date of the latest printed issue, have been given the date October 2010.

An overview of DNV service documents, their update status and historical “amendments and corrections” may be found through http://www.dnv.com/resources/rules_standards/.

- **Main changes**

Since the previous edition (October 2002), this document has been amended, most recently in October 2008. All changes have been incorporated and a new date (October 2010) has been given as explained under “General”.

CONTENTS

Part 1. Buckling Strength of Plated Structures - Conventional Buckling Code..... 6

1 Introduction.....	6
1.1 General.....	6
1.2 Symbols.....	6
2 Safety format.....	7
3 General design considerations for flat plate structures.....	8
3.1 Introduction.....	8
3.2 Definitions.....	8
3.3 Failure modes.....	8
3.4 Tolerance requirements.....	8
3.5 Serviceability limit states.....	8
3.6 Validity.....	8
4 Analysis Strategies.....	11
4.1 General.....	11
4.2 Plated structure assumed to resist shear only.....	11
4.3 Consideration of shear lag effects.....	11
4.4 Determination of buckling resistance based upon linear elastic buckling stress.....	11
5 Lateral loaded plates.....	11
6 Buckling of unstiffened plates.....	12
6.1 General.....	12
6.2 Buckling of unstiffened plates under longitudinally uniform compression.....	12
6.3 Buckling of unstiffened plates with transverse compression.....	12
6.4 Buckling of unstiffened plate with shear.....	13
6.5 Buckling of unstiffened biaxially loaded plates with shear.....	13
6.6 Buckling of unstiffened plates with varying longitudinal stress. Internal compression elements.....	14
6.7 Buckling of outstand compression elements.....	15

6.8 Buckling of unstiffened plates with varying transverse stress.....	15
6.9 Buckling of unstiffened plate with longitudinal and transverse varying stress and with shear stress.....	15
7 Buckling of stiffened plates.....	17
7.1 General.....	17
7.2 Forces in the idealised stiffened plate.....	17
7.3 Effective plate width.....	18
7.4 Resistance of plate between stiffeners.....	18
7.5 Characteristic buckling strength of stiffeners.....	19
7.6 Resistance of stiffened panels to shear stresses.....	20
7.7 Interaction formulas for axial compression and lateral pressure.....	21
7.8 Check for shear force.....	22
8 Buckling of girders.....	23
8.1 General.....	23
8.2 Girder forces.....	23
8.3 Resistance parameters for girders.....	24
8.4 Effective widths of girders.....	24
8.5 Torsional buckling of girders.....	25
9 Local buckling of stiffeners, girders and brackets	26
9.1 Local buckling of stiffeners and girders.....	26
9.2 Buckling of brackets.....	26
10 Commentary.....	27

Part 2. Buckling Strength of Plated Structures - PULS Buckling Code... 30

1 Introduction.....	30
1.1 General.....	30
1.2 Purpose.....	31
1.3 Theoretical background.....	31
1.4 Code principles.....	31
1.5 Safety formats.....	31
1.6 PULS software features.....	33
1.7 References.....	33

Introduction

This document describes two different, but equally acceptable methods, for buckling and ultimate strength assessment of plated structures.

The first method, as given in **Part 1**, is a conventional buckling code for stiffened and unstiffened panels of steel. It is an update and development of the stiffened flat plate part of previous DNV Classification Note No. 30.1 “Buckling Strength Analysis”. Recommendations are given for plates, stiffeners and girders.

The second method, as given in **Part 2**, is a computerised semi-analytical model called PULS (Panel Ultimate Limit State). It is based on a recognized non-linear plate theory, Rayleigh-Ritz discretizations of deflections and a numerical procedure for solving the equilibrium equations. The method is essentially geometrically non-linear with stress control in critical positions along plate edges and plate stiffener junction lines for handling material plasticity. The procedure provides estimates of the ultimate buckling capacity to be used in extreme load design (ULS philosophy). The buckling limit is also assessed as it may be of interest in problems related to functional requirements, i.e. for load conditions and structural parts in which elastic buckling and thereby large elastic displacements are not acceptable (SLS philosophy). The PULS code is supported by official stand alone DNV Software programs. It is also implemented as a postprocessor in other DNV programs.

Part 1.

Buckling Strength of Plated Structures - Conventional Buckling Code

1 Introduction

1.1 General

This document gives design recommendations to flat steel plate structures intended for marine structures. The RP is intended to supplement the DNV Offshore standards DNV-OS-C101 and is intended to be used for design of structures according to this standard.

1.2 Symbols

The following symbols apply to this document:

A	cross sectional area
A _e	effective area
A _f	cross sectional area of flange
A _G	cross-sectional area of girder
A _s	cross sectional area of stiffener
A _w	cross sectional area of web
C	factor
C _x	buckling factor for stresses in x-direction
C _{xs}	effective width factor due to stresses in x-direction
C _{ys}	effective width factor due to stresses in y-direction
C ₀	factor
E	Young's modulus of elasticity, 2.1·10 ⁵ MPa
G	shear modulus
I	moment of inertia
I _p	polar moment of inertia
I _{po}	polar moment of inertia = $\int r^2 dA$ where r is measured from the connection between the stiffener and the plate
I _s	moment of inertia of stiffener with full plate width
I _z	moment of inertia of stiffener about z-axis
L	length, distance
L _P	length of panel
L _G	length of girder
L _{Gk}	buckling length of girder
L _{GT}	distance between lateral support of girder
L _{GT0}	limiting distance between lateral support of girder
M _{p,Rd}	design bending moment resistance on plate side
M _{pl,Rd}	design plastic bending moment resistance
M _{Rd}	design bending moment resistance
M _{Sd}	design bending moment
M _{s,Rd}	design bending moment resistance on stiffener side
M _{st,Rd}	design bending moment resistance on stiffener side in tension

N _E	Euler buckling strength
N _{ks,Rd}	design stiffener induced axial buckling resistance
N _{kp,Rd}	design plate induced axial buckling resistance
N _{Sd}	design axial force
P _{Sd}	design lateral force
Q	Factor
V _{Rd}	design shear resistance
V _{Sd}	design shear force
W	elastic section modulus
W _{eG}	effective section modulus on girder flange side
W _{ep}	effective section modulus on plate side
W _{es}	effective section modulus on stiffener side
b	width of flange
b _e	effective width
c	length of plate outstand, Factor
c _i	interaction factor
e _f	flange eccentricity
f _{cr}	elastic plate buckling strength
f _d	design yield strength
f _E	Euler buckling strength
f _{Epx}	Euler buckling strength for plate due to longitudinal stresses
f _{Epy}	Euler buckling strength for plate due to transverse stresses
f _{Ept}	Euler buckling shear strength for plate
f _{ET}	torsional elastic buckling strength
f _{ETG}	torsional elastic buckling strength for girders
f _{Ey} , f _{Ez}	Euler buckling strength corresponding to the member y and z axis respectively
f _k	characteristic buckling strength
f _r	characteristic strength
f _T	characteristic torsional buckling strength
f _{TG}	characteristic torsional buckling strength for girders
f _y	characteristic yield strength
h	height
h _w	height of stiffener web
h _{wG}	height of girder web
i	radius of gyration
i _e	effective radius of gyration
k, k _g	buckling factor
k _c	factor
k _p	reduction factor for plate buckling due to lateral pressure
k _σ	buckling factor for unstiffened plates
l	length, element length
l _e	effective length
C	stiffener buckling length
l _l	length of longitudinal web stiffener
l _t	length of transverse web stiffener
l _T	distance between sideways support of stiffener
l ₁	length to reference point

p_f	lateral pressure giving yield in outer-fibre of a continuous stiffener using elastic section modules
p_{Sd}	design hydrostatic pressure, design lateral pressure
p_0	equivalent lateral pressure
q_{Sd}	design lateral line load
r	radius, factor
s	plate width, stiffener spacing
s_e	effective width of stiffened plate
t	thickness
t_b	bracket thickness
t_f	flange thickness
t_w	web thickness
z_p, z_t	distance
z	distance
β	Factor
γ_f	partial factor for actions
γ_M	resulting material factor
ε	Factor
$\bar{\lambda}$	reduced slenderness, column slenderness parameter
$\bar{\lambda}_e$	reduced equivalent slenderness
$\bar{\lambda}_G$	reduced slenderness
$\bar{\lambda}_p$	reduced plate slenderness
$\bar{\lambda}_T$	reduced torsional slenderness
$\bar{\lambda}_{TG}$	reduced torsional slenderness for girders
$\bar{\lambda}_\tau$	reduced slenderness
μ	coefficient, geometric parameter
ν	Poisson's ratio
$\sigma_{j,Sd}$	design von Mises' equivalent stress
$\sigma_{y1,Sd}$	larger design stress in the transverse direction, with tensile stresses taken as negative
$\sigma_{y2,Sd}$	smaller design stress in the transverse direction, with tensile stresses taken as negative
τ_{ceg}, τ_{cel}	elastic buckling strength
τ_{crg}, τ_{crl}	critical shear stress
τ_{Rd}	design resistance shear stress
τ_{Sd}	design shear stress
Ψ, Ψ_x, Ψ_y	factors

2 Safety format

This Recommended Practice is written in the load and resistance factor design format (LRFD format) to suit the DNV Offshore Standard DNV-OS-C101. This standard make use of material (resistance) and loadfactors as safety factors.

This Recommended Practice may be used in combination with a working stress design format (WSD) by the following method. For the formulas used in this standard use a material factor $\gamma_M = 1.15$. The checks should be made using a modified allowable usage factor taken as $UF \cdot 1.15$, where UF is the allowable usage factor according to the WSD standard.

3 General design considerations for flat plate structures

3.1 Introduction

The structural stability shall be checked for the structure as a whole and for each structural member.

Buckling strength analyses shall be based on the characteristic buckling strength for the most unfavourable buckling mode.

The characteristic buckling strength shall be based on the lower 5th percentile of test results. In lieu of more relevant information or more refined analysis, characteristic buckling strength may be obtained from this note.

3.2 Definitions

Notation of plate elements are shown in Figure 3-1. The plate panel may be the web or the flange of a beam, or a part of box girders, bulkheads, pontoons, hull or integrated plated decks.

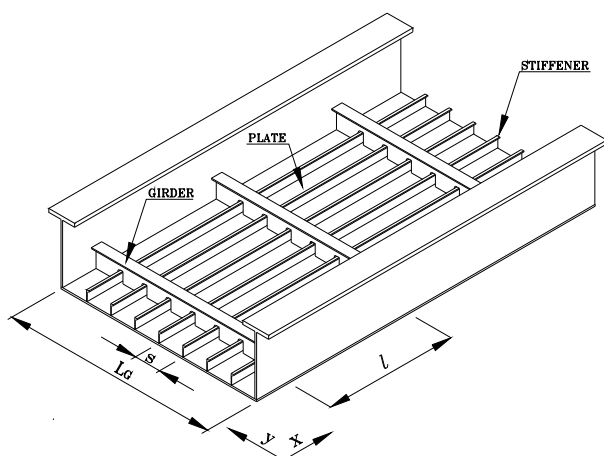

Figure 3-1 Stiffened plate panel

3.3 Failure modes

This recommended practice addresses failure modes for unstiffened and stiffened plates, which are not covered by the cross sectional check of members. (See DNV-OS-C101 Sec.5 A 400.) Such failure modes are:

- Yielding of plates in bending due to lateral load.
- Buckling of slender plates (high span to thickness ratio) due to in-plane compressive stresses or shear stresses.

Guidance for determining resistance is given both for individual plates (unstiffened plates), stiffened plates and for girders supporting stiffened plate panels. For stiffened panels the recommendations cover panel buckling, stiffener buckling as well as local buckling of stiffener and girder flanges, webs and brackets. See Table 3-1.

3.4 Tolerance requirements

The recommendations are applicable for structures built according to DNV-OS-C401 Fabrication and Testing of Offshore Structures or normal ship classification standards. See also Commentary Chapter 10.

3.5 Serviceability limit states

Check of serviceability limit states for slender plates related to out of plane deflection may normally be omitted if the smallest span of the plate is less than 120 times the plate thickness. See also Commentary to 6 in Chapter 10.

3.6 Validity

This Recommended Practice is best suited to rectangular plates and stiffened panels with stiffener length being larger than the stiffener spacing ($l > s$). It may also be used for girders being orthogonal to the stiffeners and with the girder having significant larger cross-sectional dimensions than the stiffeners.

Table 3-1 Reference table for buckling checks of plates				
Description	Load	Sketch	Clause reference	Limiting value
Unstiffened plate	Longitudinal compression		6.2	$s < l$ Buckling check not necessary if $\frac{s}{t} \leq 42 \epsilon$
Unstiffened plate	Transverse compression		6.3	$s < l$ Buckling check not necessary if $\frac{s}{t} \leq 5.4 \epsilon$
Unstiffened plate	Shear stress		6.4	$s < l$ Buckling check not necessary if $\frac{s}{t} \leq 70 \epsilon$
Unstiffened plate	Linear varying longitudinal compression		6.6	$s < l$ Buckling check not necessary if $\frac{s}{t} \leq 42 \epsilon$
Unstiffened plate	Linear varying transverse compression		6.8	$s < l$ Buckling check not necessary if $\frac{s}{t} \leq 5.4 \epsilon$

$\epsilon = \sqrt{235/f_y}$ $\epsilon = 1.0$ for $f_y = 235$ MPa $\epsilon = 0.814$ for $f_y = 355$ MPa

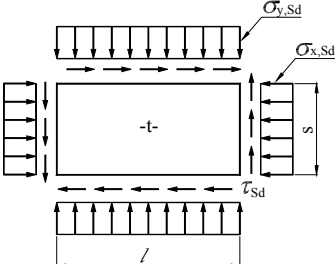
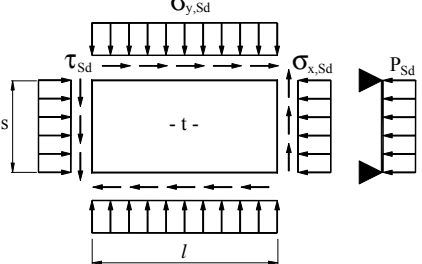
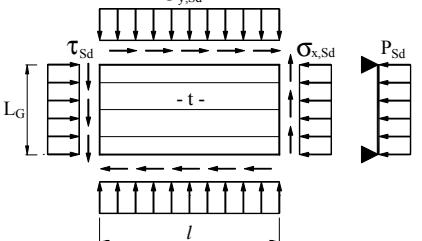
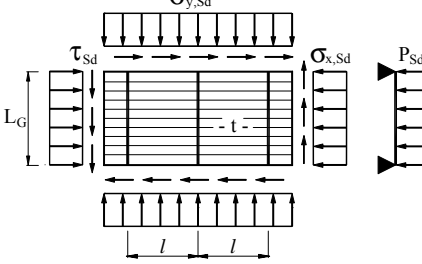
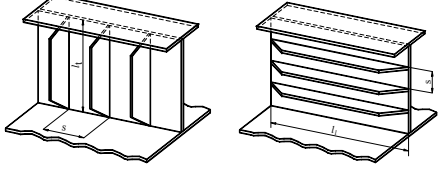
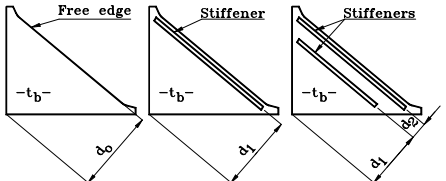
Description	Load	Sketch	Clause reference	Limiting value
Unstiffened plate	Combined longitudinal and transverse compression and shear		6.5	$s < l$ Buckling check not necessary if $\frac{s}{t} \leq 5.4\epsilon$
Unstiffened plate	Uniform lateral load and in-plane normal and shear stresses		5 and 6.5	$s < l$ Buckling check not necessary if $\frac{s}{t} \leq 5.4\epsilon$
Longitudinal stiffened plate panel	Longitudinal and transverse compression combined with shear and lateral load		5 and 7	
Girder supporting stiffened panel	Longitudinal and transverse compression combined with shear and lateral load		5 and 8	
Stiffeners to girder webs	Longitudinal and transverse compression combined with shear and lateral load		9.1	
Brackets			9.2	

$\epsilon = \sqrt{235/f_y}$ $\epsilon = 1.0$ for $f_y = 235$ MPa $\epsilon = 0.814$ for $f_y = 355$ MPa

4 Analysis Strategies

4.1 General

The design check of plated structures are normally made with linear elastic finite element analyses for determination of load effects. Flat plate structures will redistribute compressive stresses to the edges as the load approaches the resistance of the plate and the plate will cease to behave linearly. Linear finite element analyses will generally be adequate as long as the resistance is checked for the resultants from the integrated stresses in the analyses.

As slender plates under compressive loading will tend to redistribute stresses to the edges, an analysis where the part of the structure subject to buckling is given reduced stiffness may lead to more efficient structures. The adjoining structure need to be checked on the basis of the same model.

4.2 Plated structure assumed to resist shear only

The following design philosophy may be used for plate panels which main function is to carry in-plane shear loads. These plated structures may be analysed and checked by considering the plates as pure shear panels. Such panels may be decks or walls in topside modules. Then all axial membrane stresses need to be carried by the adjoining framing only which should be analysed and checked accordingly. The analysis may be carried out with the plate panels modelled with elements that are only given shear stiffness.

4.3 Consideration of shear lag effects

If the stresses are determined from beam theory, the effect of shear deformations of wide flanges need to be considered. See also Commentary to 7 in Chapter 10.

4.4 Determination of buckling resistance based upon linear elastic buckling stress

The buckling resistance may be based on linear elastic buckling stress provided the following effects are accounted for:

- Material non-linearities
- Imperfections
- Residual stresses
- Possible interaction between local and global buckling modes

See also Commentary Chapter 10.

5 Lateral loaded plates

For plates subjected to lateral pressure, either alone or in combination with in-plane stresses, the stresses may be checked by the following formula:

$$p_{Sd} \leq 4.0 \frac{f_y}{\gamma_M} \left(\frac{t}{s}\right)^2 \left[\Psi_y + \left(\frac{s}{l}\right)^2 \Psi_x \right] \quad (5.1)$$

where

p_{Sd} = design lateral pressure

$$\Psi_y = \frac{1 - \left(\frac{\sigma_{j,Sd}}{f_y}\right)^2}{\sqrt{1 - \frac{3}{4} \left(\frac{\sigma_{x,Sd}}{f_y}\right)^2 - 3 \left(\frac{\tau_{Sd}}{f_y}\right)^2}} \quad (5.2)$$

$$\Psi_x = \frac{1 - \left(\frac{\sigma_{j,Sd}}{f_y}\right)^2}{\sqrt{1 - \frac{3}{4} \left(\frac{\sigma_{y,Sd}}{f_y}\right)^2 - 3 \left(\frac{\tau_{Sd}}{f_y}\right)^2}} \quad (5.3)$$

$$\sigma_{j,Sd} = \sqrt{\sigma_{x,Sd}^2 + \sigma_{y,Sd}^2 - \sigma_{x,Sd} \cdot \sigma_{y,Sd} + 3\tau_{Sd}^2} \quad (5.4)$$

This formula for the design of a plate subjected to lateral pressure is based on yield-line theory, and accounts for the reduction of the moment resistance along the yield-line due to applied in-plane stresses. The reduced resistance is calculated based on von Mises' equivalent stress. It is emphasised that the formulation is based on a yield pattern assuming yield lines along all four edges, and will give uncertain results for cases where yield-lines can not be developed along all edges. Furthermore, since the formula does not take account of second-order effects, plates subjected to compressive stresses shall also fulfil the requirements of Chapter 6 and 7 whichever is relevant.

6 Buckling of unstiffened plates

6.1 General

This section presents recommendations for calculating the buckling resistance of unstiffened plates.

For plates that are part of a stiffened panel, the plate are checked as part of the buckling checks according to Chapter 7. Then additional check of the plate according to this section is not required.

Buckling checks of unstiffened plates in compression shall be made according to the effective width method. The reduction in plate resistance for in-plane compressive forces is expressed by a reduced (effective) width of the plate which is multiplied by the design yield strength to obtain the design resistance, see Figure 6-1 .

See also Commentary Chapter 10.

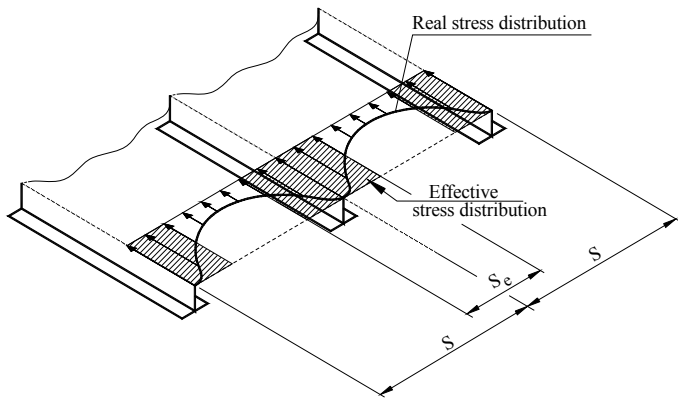

Figure 6-1 Effective width concept

6.2 Buckling of unstiffened plates under longitudinally uniform compression

The design buckling resistance of an unstiffened plate under longitudinal compression force may be calculated as:

$$\sigma_{x,Rd} = C_x \cdot \frac{f_y}{\gamma_M} \quad (6.1)$$

where

$$C_x = 1 \quad \text{when } \bar{\lambda}_p \leq 0.673 \quad (6.2)$$

$$C_x = \frac{(\bar{\lambda}_p - 0.22)}{\bar{\lambda}_p^2} \quad \text{when } \bar{\lambda}_p > 0.673$$

where $\bar{\lambda}_p$ is the plate slenderness given by:

$$\bar{\lambda}_p = \sqrt{\frac{f_y}{f_{cr}}} = 0.525 \frac{s}{t} \sqrt{\frac{f_y}{E}} \quad (6.3)$$

in which

s = plate width

t = plate thickness

f_{cr} = critical plate buckling strength

The resistance of the plate is satisfactory when:

$$\sigma_{x,Sd} \leq \sigma_{x,Rd} \quad (6.4)$$

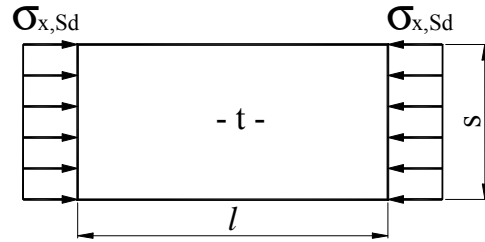

Figure 6-2 Plate with longitudinal compression

6.3 Buckling of unstiffened plates with transverse compression

The design buckling resistance of a plate under transverse compression force may be found from:

$$\sigma_{y,Rd} = \frac{\sigma_{y,R}}{\gamma_M} \quad (6.5)$$

$$\sigma_{y,R} = \left[\frac{1.3 \cdot t}{l} \cdot \sqrt{\frac{E}{f_y}} + \kappa \cdot \left(1 - \frac{1.3 \cdot t}{l} \cdot \sqrt{\frac{E}{f_y}} \right) \right] \cdot f_y \cdot k_p \quad (6.6)$$

where:

$$\kappa = 1.0 \quad \text{for } \lambda_c \leq 0.2 \quad (6.7)$$

$$\kappa = \frac{1}{2 \cdot \bar{\lambda}_c^2} \cdot \left(1 + \mu + \bar{\lambda}_c^2 - \sqrt{(1 + \mu + \bar{\lambda}_c^2)^2 - 4 \cdot \bar{\lambda}_c^2} \right) \quad \text{for } 0.2 < \bar{\lambda}_c < 2.0$$

$$\kappa = \frac{1}{2 \cdot \bar{\lambda}_c^2} + 0.07 \quad \text{for } \bar{\lambda}_c \geq 2.0$$

and $\bar{\lambda}_c$ is:

$$\bar{\lambda}_c = 1.1 \cdot \frac{s}{t} \cdot \sqrt{\frac{f_y}{E}} \quad (6.8)$$

and μ is:

$$\mu = 0.21 \cdot (\bar{\lambda}_c - 0.2) \quad (6.9)$$

t = plate thickness

l = plate length

s = plate width

The reduction factor due to lateral load k_p may, in lieu of more accurate results, be calculated as:

$$k_p = 1.0 \quad \text{for} \quad p_{Sd} \leq 2 \cdot \left(\frac{t}{s}\right)^2 \cdot f_y \quad (6.10)$$

otherwise

$$k_p = 1.0 - h_\alpha \cdot \left(\frac{p_{Sd}}{f_y} - 2 \cdot \left(\frac{t}{s}\right)^2\right), \quad \text{but } k_p \geq 0$$

where

$$h_\alpha = 0.05 \cdot \frac{s}{t} - 0.75 \quad \text{but } h_\alpha \geq 0 \quad (6.11)$$

The resistance of the plate is satisfactory when:

$$\sigma_{y,Sd} \leq \sigma_{y,Rd} \quad (6.12)$$

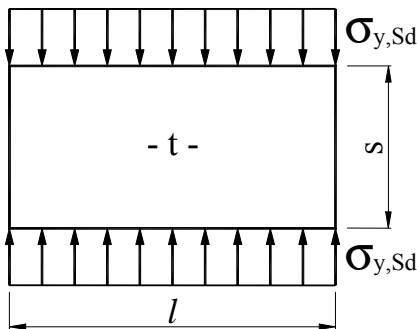

Figure 6-3 Plate with transverse compression

6.4 Buckling of unstiffened plate with shear

Shear buckling of a plate can be checked by

$$\tau_{Sd} \leq \tau_{Rd} \quad (6.13)$$

$$\tau_{Rd} = \frac{C_\tau}{\gamma_M} \cdot \frac{f_y}{\sqrt{3}} \quad (6.14)$$

where

$$C_\tau = 1.0 \quad \text{for} \quad \bar{\lambda}_w \leq 0.8 \quad (6.15)$$

$$C_\tau = 1.0 - 0.625 (\bar{\lambda}_w - 0.8), \quad \text{for } 0.8 < \bar{\lambda}_w \leq 1.2$$

$$C_\tau = \frac{0.9}{\bar{\lambda}_w}, \quad \text{for } \bar{\lambda}_w > 1.2$$

$$\bar{\lambda}_w = 0.795 \cdot \frac{s}{t} \cdot \sqrt{\frac{f_y}{E \cdot k_l}} \quad (6.16)$$

$$k_l = 5.34 + 4 \left(\frac{s}{l}\right)^2, \quad \text{for } l \geq s \quad (6.17)$$

$$= 5.34 \left(\frac{s}{l}\right)^2 + 4, \quad \text{for } l < s$$

6.5 Buckling of unstiffened biaxially loaded plates with shear

A plate subjected to biaxially loading with shear should fulfil the following requirement:

$$\left(\frac{\sigma_{x,Sd}}{\sigma_{x,Rd}}\right)^2 + \left(\frac{\sigma_{y,Sd}}{\sigma_{y,Rd}}\right)^2 - c_i \cdot \left(\frac{\sigma_{x,Sd}}{\sigma_{x,Rd}}\right) \cdot \left(\frac{\sigma_{y,Sd}}{\sigma_{y,Rd}}\right) + \left(\frac{\tau_{Sd}}{\tau_{Rd}}\right)^2 \leq 1.0 \quad (6.18)$$

where if both $\sigma_{x,Sd}$ and $\sigma_{y,Sd}$ is compression (positive) then

$$c_i = 1 - \frac{s}{120 \cdot t} \quad \text{for } \frac{s}{t} \leq 120$$

$$c_i = 0 \quad \text{for } \frac{s}{t} > 120$$

If either of $\sigma_{x,Sd}$ and $\sigma_{y,Sd}$ or both is in tension (negative), then $c_i = 1.0$.

$\sigma_{x,Rd}$ is given by eq. (6.1) and $\sigma_{y,Rd}$ is given by eq. (6.5). In case of tension, apply f_y/γ_M .

τ_{Rd} is given by eq. (6.19) in cases where $\sigma_{y,Sd}$ is positive (compression) and by eq. (6.14) in cases where $\sigma_{y,Sd}$ is zero or negative (in tension).

$$\tau_{Rd} = \frac{C_{\tau e}}{\gamma_M} \cdot \frac{f_y}{\sqrt{3}} \quad (6.19)$$

$$C_{\tau e} = 1.0 \quad \text{for} \quad \bar{\lambda}_w \leq 0.8 \quad (6.20)$$

$$C_{\tau e} = 1.0 - 0.8 \cdot (\bar{\lambda}_w - 0.8), \quad \text{for } 0.8 < \bar{\lambda}_w \leq 1.25$$

$$C_{\tau e} = \frac{1.0}{\bar{\lambda}_w^2}, \quad \text{for } \bar{\lambda}_w > 1.25$$

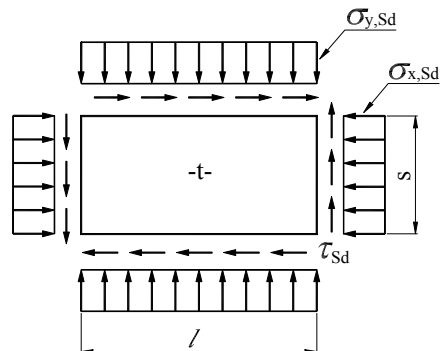

Figure 6-4 Biaxially loaded plate with shear

6.6 Buckling of unstiffened plates with varying longitudinal stress. Internal compression elements

The buckling resistance of an unstiffened plate with varying longitudinal stress may be found from:

$$\sigma_{x,Rd} = C_x \frac{f_y}{\gamma_M} \quad (6.21)$$

where

$$C_x = 1 \quad \text{when } \bar{\lambda}_p \leq 0.673 \quad (6.22)$$

$$C_x = \frac{\bar{\lambda}_p - 0.055 \cdot (3 + \psi)}{\bar{\lambda}_p^2} \quad \text{when } \bar{\lambda}_p > 0.673 \quad (6.23)$$

where $\bar{\lambda}_p$ is the plate slenderness given by:

$$\bar{\lambda}_p = \sqrt{\frac{f_y}{f_{cr}}} = \frac{s}{t} \cdot \frac{1}{28.4 \varepsilon \sqrt{k_\sigma}} \quad (6.24)$$

in which

s = plate width

$\psi = \sigma_2 / \sigma_1$ Stress ratio. σ_1 is largest stress with compressive stress taken as positive.

t = plate thickness

f_{cr} = critical plate buckling strength

$$\varepsilon = \sqrt{\frac{235}{f_y}}$$

$$k_\sigma = \frac{8.2}{1.05 + \psi} \quad \text{when } 0 \leq \psi \leq 1$$

$$= 7.81 - 6.29\psi + 9.78\psi^2 \quad \text{when } -1 \leq \psi < 0$$

$$= 5.98(1 - \psi)^2 \quad \text{when } -2 \leq \psi < -1$$

The resistance of the plate is satisfactory when:

$$\sigma_{x,Sd} \leq \sigma_{x,Rd} \quad (6.25)$$

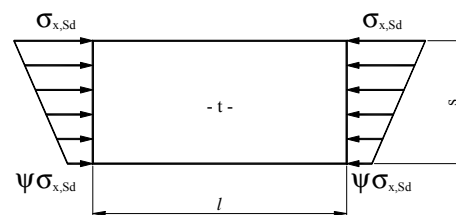

Figure 6-5 Plate with varying longitudinal stress

In order to perform cross sectional checks for members subjected to plate buckling the local buckling effects can be accounted for by checking the resistance by using the effective width according to Table 6-1.

Table 6-1 Effective width for internal compression plate elements		
Stress distribution (compression positive)		Effective width b_{eff}
	$\psi = 1$	$b_{eff} = C_x \cdot b$ $b_{e1} = 0.5 b_{eff}$ $b_{e2} = 0.5 b_{eff}$
	$1 > \psi > 0$	$b_{eff} = C_x \cdot b$ $b_{e1} = \frac{2}{5 - \psi} b_{eff}$ $b_{e2} = b_{eff} - b_{e1}$
	$\psi < 0$	$b_{eff} = C_x \cdot b_c = \frac{C_x \cdot b}{1 - \psi}$ $b_{e1} = 0.4 b_{eff}$ $b_{e2} = 0.6 b_{eff}$

6.7 Buckling of outstand compression elements

The buckling resistance of an outstand compression element with varying or constant longitudinal stress may be found from:

$$\sigma_{x,Rd} = C_x \frac{f_y}{\gamma_M} \quad (6.26)$$

where

$$C_x = 1 \quad \text{when } \bar{\lambda}_p \leq 0.749 \quad (6.27)$$

$$C_x = \frac{\bar{\lambda}_p - 0.188}{\bar{\lambda}_p^2} \quad \text{when } \bar{\lambda}_p > 0.749 \quad (6.28)$$

where $\bar{\lambda}_p$ is the plate slenderness given by:

$$\bar{\lambda}_p = \sqrt{\frac{f_y}{f_{cr}}} = \frac{s}{t} \cdot \frac{1}{28.4 \varepsilon \sqrt{k_\sigma}} \quad (6.29)$$

in which

s = plate width

t = plate thickness

f_{cr} = critical plate buckling strength

$$\varepsilon = \sqrt{\frac{235}{f_y}}$$

For outstand with largest compression stress at free edge:

$$k_\sigma = 0.57 - 0.21 \psi + 0.07 \psi^2 \quad \text{when } -3 \leq \psi \leq 1$$

For outstand with largest compression stress at supported edge:

$$k_\sigma = \frac{0.578}{0.34 + \psi} \quad \text{when } 0 \leq \psi \leq 1$$

$$k_\sigma = 1.7 - 5 \psi + 17.1 \psi^2 \quad \text{when } -1 \leq \psi < 0$$

Cross sectional checks of members subjected to plate buckling local buckling effects can be accounted for by checking the resistance by using the effective width according to Table 6-2 and Table 6-3 for outstand elements with largest compression stress at free edge or supported edge respectively.

6.8 Buckling of unstiffened plates with varying transverse stress

In case of linear varying transverse stress the capacity check can be done by use of the design stress value at a distance l_1 from the most stressed end of the plate, but not less than 0.75 of maximum $\sigma_{y,Sd}$. The resistance $\sigma_{y,Rd}$ should be calculated from eq. (6.5).

l_1 = minimum of 0.25 l and 0.5 s

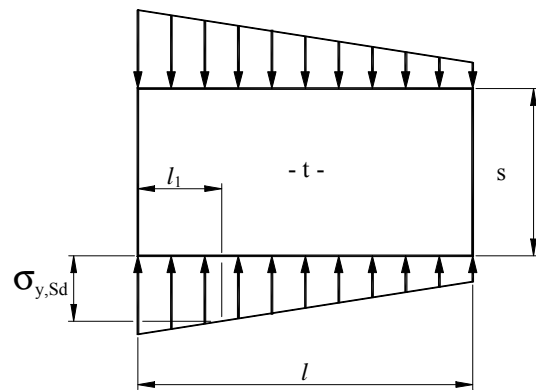

Figure 6-6 Linear varying stress in the transverse direction

6.9 Buckling of unstiffened plate with longitudinal and transverse varying stress and with shear stress

The check of combined varying loads may be done according to eq. (6.18) with the resistance calculated according to eq. (6.21) and eq. (6.5) using the stress point defined in sec. 6.8.

Table 6-2 Effective width for outstand compression plate elements with largest stress at free edge		
Stress distribution (compression positive)		Effective width b_{eff}
	$0 < \psi \leq 1$	$b_{\text{eff}} = C_x \cdot c$
	$\psi < 0$	$b_{\text{eff}} = C_x \cdot b_c = \frac{C_x \cdot c}{1 - \psi}$

Table 6-3 Effective width for outstand compression plate elements with largest stress at supported edge		
Stress distribution (compression positive)		Effective width b_{eff}
	$0 < \psi \leq 1$	$b_{\text{eff}} = C_x \cdot c$
	$\psi < 0$	$b_{\text{eff}} = C_x \cdot b_c = \frac{C_x \cdot c}{1 - \psi}$

7 Buckling of stiffened plates

7.1 General

This chapter deals with stiffened plate panels subjected to axial stress in two directions, shear stress and lateral load.

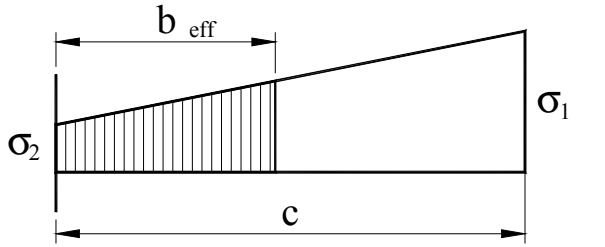
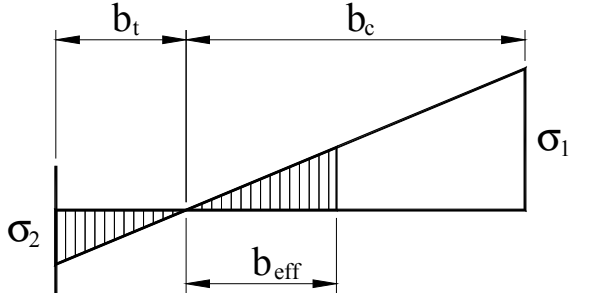
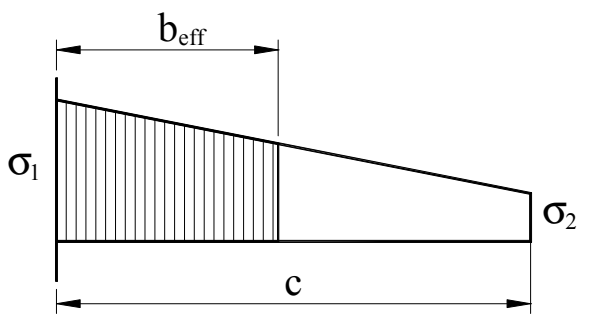
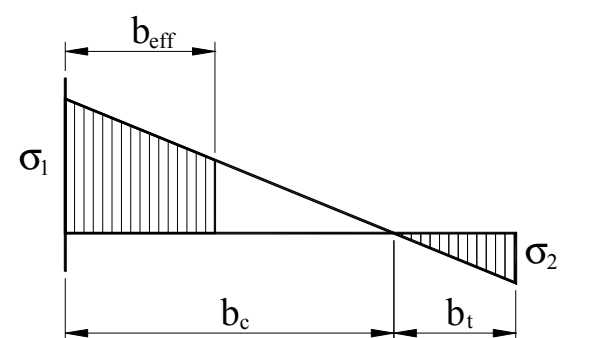
There are different formulas for stiffeners being continuous (or connected to frames with their full moment resistance) and simple supported (sniped) stiffeners.

An example of a stiffened plate panel is shown in Figure 3-1.

The stiffener cross section needs to fulfil requirements to avoid local buckling given in Chapter 9.

For shear lag effects see Commentary Chapter 10.

The plate between stiffeners will normally be checked implicitly by the stiffener check since plate buckling is accounted for by the effective width method. However, in cases where $\sigma_{y,Sd}$ stress is the dominant stress it is necessary to check the plate resistance according to eq. (7.19).

For slender stiffened plates the load carrying resistance in the direction transverse to the stiffener may be neglected. Then $\sigma_{y,Sd}$ stresses may be assumed to be carried solely by the girder. In such cases the effective girder flange may be determined by disregarding the stiffeners, and the stiffener with plate may be checked by neglecting $\sigma_{y,Sd}$ stresses (method 2 in sec. 8.4). See also Commentary to 8 in Chapter 10.

7.2 Forces in the idealised stiffened plate

Stiffened plates subjected to combined forces, see Figure 7-1 should be designed to resist an equivalent axial force according to eq. (7.1) and an equivalent lateral load according to eq. (7.8).

The equivalent axial force should be taken as:

$$N_{Sd} = \sigma_{x,Sd}(A_s + st) + \tau_{tf}st \quad (7.1)$$

where

A_s = cross sectional area of stiffener

s = distance between stiffeners

t = plate thickness

$\sigma_{x,Sd}$ = axial stress in plate and stiffener with compressive stresses as positive

$$\tau_{tf} = \tau_{Sd} - \tau_{crf} \quad \text{for } \tau_{Sd} > \frac{\tau_{crf}}{\gamma_M} \quad (7.2)$$

and tension field action is allowed

$$\tau_{tf} = 0 \quad \text{otherwise} \quad (7.3)$$

Assumption of tension field action implies that no (or negligible) resistance of the plate against transverse compression stresses (σ_y) can be assumed. See also Commentary Chapter 10.

τ_{crf} = critical shear stress for the plate with the stiffeners removed, according to eq. (7.4).

τ_{crf} = critical shear stress for the plate panel between two stiffeners, according to eq. (7.6).

$$\tau_{crf} = k_g \cdot 0.904 \cdot E \cdot \left(\frac{t}{l}\right)^2 \quad (7.4)$$

where :

$$k_g = 5.34 + 4\left(\frac{l}{L_G}\right)^2, \quad \text{for } l \leq L_G \quad (7.5)$$

$$= 5.34\left(\frac{l}{L_G}\right)^2 + 4, \quad \text{for } l > L_G$$

L_G = Girder length see Figure 3-1

$$\tau_{crf} = k_l \cdot 0.904 \cdot E \cdot \left(\frac{t}{s}\right)^2 \quad (7.6)$$

where:

$$k_l = 5.34 + 4\left(\frac{s}{l}\right)^2, \quad \text{for } l \geq s \quad (7.7)$$

$$= 5.34\left(\frac{s}{l}\right)^2 + 4, \quad \text{for } l < s$$

The equivalent lateral line load should be taken as:

$$q_{Sd} = (p_{Sd} + p_0)s \quad (7.8)$$

p_0 shall be applied in the direction of the external pressure p_{Sd} . For situations where p_{Sd} is less than p_0 , the stiffener need to be checked for p_0 applied in both directions (i.e. at plate side and stiffener side).

p_{Sd} = design lateral pressure

s = stiffener spacing

$$p_0 = (0.6 + 0.4\psi) C_0 \sigma_{y1,Sd} \quad \text{if } \psi > -1.5 \quad (7.9)$$

$$p_0 = 0 \quad \text{if } \psi \leq -1.5 \quad (7.10)$$

$p_0 = 0$ in case $\sigma_{y,Sd}$ is in tension along the whole length of the panel.

$$C_0 = \frac{W_{es} \cdot f_y \cdot m_c}{k_c \cdot E \cdot t^2 \cdot s} \quad (7.11)$$

$$\psi = \frac{\sigma_{y2,Sd}}{\sigma_{y1,Sd}}$$

- $\sigma_{y1,Sd}$ = larger design stress in the transverse direction, with tensile stresses taken as negative
- $\sigma_{y2,Sd}$ = smaller design stress in the transverse direction, with tensile stresses taken as negative
- W_{es} = section modulus for stiffener with effective plate at flange tip
- m_c = 13.3 for continuous stiffeners or,
= 8.9 for simple supported stiffeners (sniped stiffeners)

$$k_c = 2 \cdot \left(1 + \sqrt{1 + \frac{10.9 \cdot I_s}{t^3 \cdot s}} \right) \quad (7.12)$$

I_s = moment of inertia of stiffener with full plate width

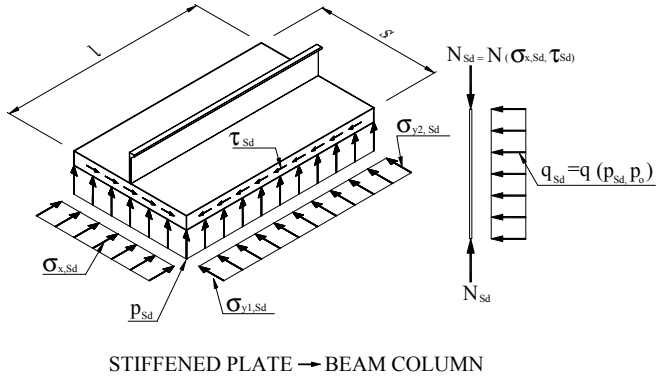

Figure 7-1 Strut model

7.3 Effective plate width

The effective plate width for a continuous stiffener subjected to longitudinal and transverse stress and shear is calculated as:

$$\frac{S_e}{s} = C_{xs} C_{ys} \quad (7.13)$$

The reduction factor due to stresses in the longitudinal direction, C_{xs} , is

$$C_{xs} = \frac{\bar{\lambda}_p - 0.22}{\bar{\lambda}_p^2}, \quad \text{if } \bar{\lambda}_p > 0.673 \quad (7.14)$$

$$= 1.0, \quad \text{if } \bar{\lambda}_p \leq 0.673$$

where

$$\bar{\lambda}_p = 0.525 \frac{s}{t} \sqrt{\frac{f_y}{E}} \quad (7.15)$$

and the reduction factor for compression stresses in the transverse direction, C_{ys} , is found from:

$$C_{ys} = \sqrt{1 - \left(\frac{\sigma_{y,Sd}}{\sigma_{y,R}} \right)^2} + c_i \left(\frac{\sigma_{x,Sd} \cdot \sigma_{y,Sd}}{C_{xs} \cdot f_y \cdot \sigma_{y,R}} \right) \quad (7.16)$$

where

$$c_i = 1 - \frac{s}{120 \cdot t} \quad \text{for } \frac{s}{t} \leq 120$$

$$c_i = 0 \quad \text{for } \frac{s}{t} > 120$$

$\sigma_{y,R}$ is calculated according to eq. (6.6).

In case of linear varying stress, $\sigma_{y,Sd}$ may be determined as described in sec. 6.8

The reduction factor for tension stresses in the transverse direction, C_{ys} , is calculated as:

$$C_{ys} = \frac{1}{2} \left(\sqrt{4 - 3 \left(\frac{\sigma_{y,Sd}}{f_y} \right)^2} + \frac{\sigma_{y,Sd}}{f_y} \right), \quad \text{but } C_{ys} \leq 1.0 \quad (7.17)$$

Tensile stresses are defined as negative.

The effective width for varying stiffener spacing see Figure 7-2.

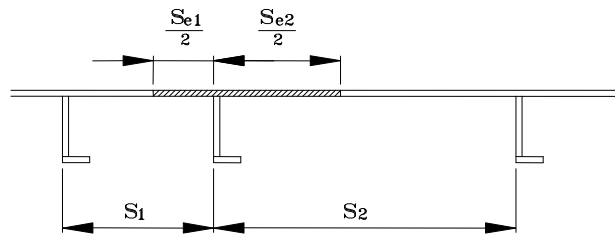

Figure 7-2 Effective widths for varying stiffener spacing

7.4 Resistance of plate between stiffeners

The plate between stiffeners shall be checked for:

$$\tau_{Sd} \leq \tau_{Rd} = \frac{f_y}{\sqrt{3} \cdot \gamma_M} \quad (7.18)$$

$$\sigma_{y,Sd} \leq k_{sp} \cdot \sigma_{y,Rd} \quad (7.19)$$

where:

$$k_{sp} = \sqrt{1.0 - 3 \cdot \left(\frac{\tau_{Sd}}{f_y} \right)^2} \quad (7.20)$$

and $\sigma_{y,Rd}$ is determined from eq. (6.5).

When this check and stiffener check according to sec. 7.7 is carried out it is not necessary to check the plate between stiffeners according to Chapter 6.

See also Commentary Chapter 10.

7.5 Characteristic buckling strength of stiffeners

7.5.1 General

The characteristic buckling strength for stiffeners may be found from:

$$\frac{f_k}{f_r} = 1 \quad \text{when } \bar{\lambda} \leq 0.2 \quad (7.21)$$

$$\frac{f_k}{f_r} = \frac{1 + \mu + \bar{\lambda}^2 - \sqrt{(1 + \mu + \bar{\lambda}^2)^2 - 4\bar{\lambda}^2}}{2\bar{\lambda}^2} \quad (7.22)$$

when $\bar{\lambda} > 0.2$

where

$$\bar{\lambda} = \sqrt{\frac{f_r}{f_E}} \quad (7.23)$$

$$f_E = \pi^2 E \left(\frac{i_e}{l_k} \right)^2 \quad (7.24)$$

for check at plate side

$$\mu = \left(0.34 + 0.08 \frac{z_p}{i_e} \right) (\bar{\lambda} - 0.2) \quad (7.25)$$

for check at stiffener side

$$\mu = \left(0.34 + 0.08 \frac{z_t}{i_e} \right) (\bar{\lambda} - 0.2) \quad (7.26)$$

where:

$$f_r = f_y \quad \text{for check at plate side}$$

$$f_r = f_y \quad \text{for check at stiffener side if } \bar{\lambda}_T \leq 0.6$$

$$f_r = f_T \quad \text{for check at stiffener side if } \bar{\lambda}_T > 0.6,$$

f_T may be calculated according to sec. 7.5.2

$$\bar{\lambda}_T \quad \text{see eq. (7.30)}$$

l_k see eq. (7.74)

$i_e = \sqrt{\frac{I_e}{A_e}}$, effective radius of gyration

I_e effective moment of inertia

A_e effective area

z_p, z_t is defined in Figure 7-3

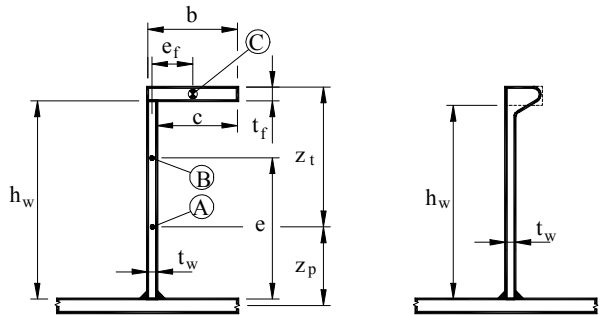
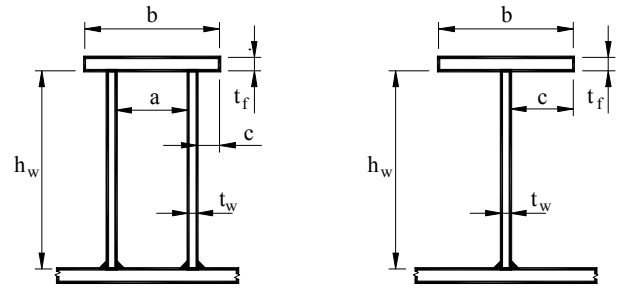

A = centroid of stiffener with effective plate flange.

B = centroid of stiffener exclusive of any plate flange.

C = centroid of flange.

Figure 7-3 Cross-sectional parameters for stiffeners and girders

7.5.2 Torsional buckling of stiffeners

The torsional buckling strength may be calculated as:

$$\frac{f_T}{f_y} = 1.0 \quad \text{when } \bar{\lambda}_T \leq 0.6 \quad (7.27)$$

$$\frac{f_T}{f_y} = \frac{1 + \mu + \bar{\lambda}_T^2 - \sqrt{(1 + \mu + \bar{\lambda}_T^2)^2 - 4\bar{\lambda}_T^2}}{2\bar{\lambda}_T^2} \quad (7.28)$$

when $\bar{\lambda}_T > 0.6$

where

$$\mu = 0.35 (\bar{\lambda}_T - 0.6) \quad (7.29)$$

$$\bar{\lambda}_T = \sqrt{\frac{f_y}{f_{ET}}} \quad (7.30)$$

Generally f_{ET} may be calculated as:

$$f_{ET} = \beta \frac{GI_t}{I_{po}} + \pi^2 \frac{Eh_s^2 I_z}{I_{po} I_T^2} \quad (7.31)$$

For L- and T-stiffeners f_{ET} may be calculated as:

$$f_{ET} = \beta \frac{A_w + \left(\frac{t_f}{t_w}\right)^2 A_f}{A_w + 3A_f} G \left(\frac{t_w}{h_w}\right)^2 + \frac{\pi^2 EI_z}{\left(\frac{A_w}{3} + A_f\right) l_T^2} \quad (7.32)$$

$$I_z = \frac{1}{12} A_f b^2 + e_f^2 \frac{A_f}{1 + \frac{A_f}{A_w}} \quad (7.33)$$

For flatbar stiffeners f_{ET} may be calculated as:

$$f_{ET} = \left[\beta + 2 \left(\frac{h_w}{l_T}\right)^2 \right] \cdot G \left(\frac{t_w}{h_w}\right)^2 \quad (7.34)$$

where

$\beta = 1.0$,
or may for stocky plates alternatively be calculated as per eq. (7.35) for $s \leq l$

A_f = cross sectional area of flange

A_w = cross sectional area of web

G = shear modulus

I_{po} = polar moment of inertia = $\int r^2 dA$

where r is measured from the connection between the stiffener and the plate

I_t = stiffener torsional moment of inertia (St. Venant torsion)

I_z = moment of inertia of the stiffeners neutral axis normal to the plane of the plate

b = flange width

e_f = flange eccentricity, see Figure 7-3

h_w = web height

h_s = distance from stiffener toe (connection between stiffener and plate) to the shear centre of the stiffener

l_T = distance between sideways supports of stiffener, distance between tripping brackets (torsional buckling length).

t = plate thickness

t_f = thickness of flange

t_w = thickness of web

where

$$\beta = \frac{3C + 0.2}{C + 0.2} \quad (7.35)$$

$$C = \frac{h_w}{s} \left(\frac{t}{t_w}\right)^3 \sqrt{(1-\eta)} \quad (7.36)$$

where:

$$\eta = \frac{\sigma_{j,Sd}}{f_{ep}} \quad \eta \leq 1.0 \quad (7.37)$$

$$\sigma_{j,Sd} = \sqrt{\sigma_{x,Sd}^2 + \sigma_{y,Sd}^2 - \sigma_{x,Sd} \sigma_{y,Sd} + 3\tau_{Sd}^2} \quad (7.38)$$

$$f_{ep} = \frac{f_y}{\sqrt{1 + \lambda_c}} \quad (7.39)$$

$$\lambda_c^{-2} = \frac{f_y}{\sigma_{j,Sd}} \left[\left(\frac{\sigma_{x,Sd}}{f_{Epx}}\right)^c + \left(\frac{\sigma_{y,Sd}}{f_{Epy}}\right)^c + \left(\frac{\tau_{Sd}}{f_{Ept}}\right)^c \right]^{\frac{1}{c}} \quad (7.40)$$

where

$$c = 2 - \frac{s}{l} \quad (7.41)$$

$$f_{Epx} = 3.62E \left(\frac{t}{s}\right)^2 \quad (7.42)$$

$$f_{Epy} = 0.9E \left(\frac{t}{s}\right)^2 \quad (7.43)$$

$$f_{Ept} = 5.0E \left(\frac{t}{s}\right)^2 \quad (7.44)$$

$\sigma_{x,Sd}$ and $\sigma_{y,Sd}$ should be set to zero if in tension

7.6 Resistance of stiffened panels to shear stresses

The resistance towards shear stresses τ_{Rd} is found as the minimum of τ_{Rdy} , τ_{Rdl} and τ_{Rds} according to the following:

$$\tau_{Rdy} = \frac{f_y}{\sqrt{3} \cdot \gamma_M} \quad (7.45)$$

$$\tau_{Rdl} = \frac{\tau_{crl}}{\gamma_M} \quad (7.46)$$

$$\tau_{Rds} = \frac{\tau_{crs}}{\gamma_M} \quad (7.47)$$

where τ_{crl} is obtained from eq. (7.6) and τ_{crs} is obtained from:

$$\tau_{crs} = \frac{36 \cdot E}{s \cdot t \cdot l^2} \cdot \sqrt[4]{I_p \cdot I_s^3} \quad (7.48)$$

with:

$$I_p = \frac{t^3 \cdot s}{10.9} \quad (7.49)$$

and I_s = moment of inertia of stiffener with full plate width.

7.7 Interaction formulas for axial compression and lateral pressure

7.7.1 Continuous stiffeners

For continuous stiffeners the following four interaction equations need to be fulfilled in case of:

Lateral pressure on plate side:

$$\frac{N_{Sd}}{N_{ks,Rd}} + \frac{M_{1,Sd} - N_{Sd} \cdot z^*}{M_{s1,Rd} \left(1 - \frac{N_{Sd}}{N_E}\right)} + u \leq 1 \quad (7.50)$$

$$\frac{N_{Sd}}{N_{kp,Rd}} - 2 \cdot \frac{N_{Sd}}{N_{Rd}} + \frac{M_{1,Sd} - N_{Sd} \cdot z^*}{M_{p,Rd} \left(1 - \frac{N_{Sd}}{N_E}\right)} + u \leq 1 \quad (7.51)$$

$$\frac{N_{Sd}}{N_{ks,Rd}} - 2 \cdot \frac{N_{Sd}}{N_{Rd}} + \frac{M_{2,Sd} + N_{Sd} \cdot z^*}{M_{st,Rd} \left(1 - \frac{N_{Sd}}{N_E}\right)} + u \leq 1 \quad (7.52)$$

$$\frac{N_{Sd}}{N_{kp,Rd}} + \frac{M_{2,Sd} + N_{Sd} \cdot z^*}{M_{p,Rd} \left(1 - \frac{N_{Sd}}{N_E}\right)} + u \leq 1 \quad (7.53)$$

Lateral pressure on stiffener side:

$$\frac{N_{Sd}}{N_{ks,Rd}} - 2 \cdot \frac{N_{Sd}}{N_{Rd}} + \frac{M_{1,Sd} + N_{Sd} \cdot z^*}{M_{st,Rd} \left(1 - \frac{N_{Sd}}{N_E}\right)} + u \leq 1 \quad (7.54)$$

$$\frac{N_{Sd}}{N_{kp,Rd}} + \frac{M_{1,Sd} + N_{Sd} \cdot z^*}{M_{p,Rd} \left(1 - \frac{N_{Sd}}{N_E}\right)} + u \leq 1 \quad (7.55)$$

$$\frac{N_{Sd}}{N_{ks,Rd}} + \frac{M_{2,Sd} - N_{Sd} \cdot z^*}{M_{s2,Rd} \left(1 - \frac{N_{Sd}}{N_E}\right)} + u \leq 1 \quad (7.56)$$

$$\frac{N_{Sd}}{N_{kp,Rd}} - 2 \cdot \frac{N_{Sd}}{N_{Rd}} + \frac{M_{2,Sd} - N_{Sd} \cdot z^*}{M_{p,Rd} \left(1 - \frac{N_{Sd}}{N_E}\right)} + u \leq 1 \quad (7.57)$$

where

$$u = \left(\frac{\tau_{Sd}}{\tau_{Rd}} \right)^2 \quad (7.58)$$

When tension field action is assumed according to eq. (7.2) then $u = 0$.

For resistance parameters see sec. 7.7.3 for stiffener and sec. 8.3 for girders.

$$M_{1,Sd} = \left| \frac{q_{Sd} l^2}{12} \right| \text{ for continuous stiffeners with equal spans}$$

and equal lateral pressure in all spans
= absolute value of the actual largest support moment for continuous stiffeners with unequal spans and/or unequal lateral pressure in adjacent spans

$$M_{2,Sd} = \left| \frac{q_{Sd} l^2}{24} \right| \text{ for continuous stiffeners with equal spans}$$

and equal lateral pressure in all spans
= absolute value of the actual largest field moment for continuous stiffeners with unequal spans and/or unequal lateral pressure in adjacent spans

q_{Sd} is given in eq. (7.8)

l = span length

z^* is the distance from the neutral axis of the effective section to the working point of the axial force. z^* may be varied in order to optimise the resistance. z^* should then be selected so the maximum utilisation found from the equations (7.50) to (7.53) or (7.54) to (7.57) is at its minimum, see also Commentary Chapter 10. The value of z^* is taken positive towards the plate. The simplification $z^* = 0$ is always allowed.

7.7.2 Simple supported stiffener (sniped stiffener)

Simple supported stiffener (sniped stiffener):

Lateral pressure on plate side:

$$\frac{N_{Sd}}{N_{ks,Rd}} - 2 \cdot \frac{N_{Sd}}{N_{Rd}} + \frac{\left| \frac{q_{Sd} l^2}{8} \right| + N_{Sd} \cdot z^*}{M_{st,Rd} \left(1 - \frac{N_{Sd}}{N_E}\right)} + u \leq 1 \quad (7.59)$$

$$\frac{N_{Sd}}{N_{kp,Rd}} + \frac{\left| \frac{q_{Sd} l^2}{8} \right| + N_{Sd} \cdot z^*}{M_{p,Rd} \left(1 - \frac{N_{Sd}}{N_E}\right)} + u \leq 1 \quad (7.60)$$

Lateral pressure on stiffener side:

if $\frac{q_{Sd} l^2}{8} \geq N_{Sd} \cdot z^*$ then:

$$\frac{N_{Sd}}{N_{ks,Rd}} + \frac{\left| \frac{q_{Sd} l^2}{8} \right| - N_{Sd} \cdot z^*}{M_{s2,Rd} \left(1 - \frac{N_{Sd}}{N_E}\right)} + u \leq 1 \quad (7.61)$$

$$\frac{N_{Sd}}{N_{kp,Rd}} - 2 \cdot \frac{N_{Sd}}{N_{Rd}} + \frac{\left| \frac{q_{Sd} l^2}{8} \right| - N_{Sd} \cdot z^*}{M_{p,Rd} \left(1 - \frac{N_{Sd}}{N_E}\right)} + u \leq 1 \quad (7.62)$$

if $\frac{q_{Sd} l^2}{8} < N_{Sd} \cdot z^*$ then:

$$\frac{N_{Sd}}{N_{ks,Rd}} - 2 \cdot \frac{N_{Sd}}{N_{Rd}} + \frac{N_{Sd} \cdot z^* - \left| \frac{q_{Sd} l^2}{8} \right|}{M_{st,Rd} \left(1 - \frac{N_{Sd}}{N_E}\right)} + u \leq 1 \quad (7.63)$$

$$\frac{N_{Sd}}{N_{kp,Rd}} + \frac{N_{Sd} \cdot z^* - \left| \frac{q_{sd} l^2}{8} \right|}{M_{p,Rd} \left(1 - \frac{N_{Sd}}{N_E} \right)} + u \leq 1 \quad (7.64)$$

l = span length is given in eq. (7.58)

q_{sd} is given in eq. (7.8)

z^* is the distance from the neutral axis of the effective section to the working point of the axial force, which for a sniped stiffener will be in the centre of the plate. The value of z^* is taken positive towards the plate.

7.7.3 Resistance parameters for stiffeners.

The following resistance parameters are used in the interaction equations for stiffeners:

$$N_{Rd} = A_e \frac{f_y}{\gamma_M} \quad (7.65)$$

A_e = $(A_s + s_e t)$ effective area of stiffener and plate

A_s = cross sectional area of stiffener

s_e = effective width, see sec. 7.3

$$N_{ks,Rd} = A_e \frac{f_k}{\gamma_M} \quad (7.66)$$

where f_k is calculated from sec. 7.5 using eq. (7.26)

$$N_{kp,Rd} = A_e \frac{f_k}{\gamma_M} \quad (7.67)$$

where f_k is calculated from sec. 7.5 using eq. (7.25)

$$M_{s1,Rd} = W_{es} \frac{f_r}{\gamma_M} \quad (7.68)$$

where f_r is calculated from sec. 7.5 for stiffener side using $l_T = 0.4 l$ or distance between lateral support if this is less.

$$M_{s2,Rd} = W_{es} \frac{f_r}{\gamma_M} \quad (7.69)$$

where f_r is calculated from sec. 7.5 for stiffener side using $l_T = 0.8 l$ or distance between lateral support if this is less.

$$M_{st,Rd} = W_{es} \frac{f_y}{\gamma_M} \quad (7.70)$$

$$M_{p,Rd} = W_{ep} \frac{f_y}{\gamma_M} \quad (7.71)$$

$W_{ep} = \frac{I_e}{z_p}$, effective elastic section modulus on plate side, see Figure 7-3.

$W_{es} = \frac{I_e}{z_t}$, effective elastic section modulus on stiffener side, see Figure 7-3.

$$N_E = \frac{\pi^2 E A_e}{\left(\frac{l_k}{i_e} \right)^2} \quad (7.72)$$

where

$$i_e = \sqrt{\frac{I_e}{A_e}} \quad (7.73)$$

For a continuous stiffener the buckling length may be calculated from the following equation:

$$l_k = l \left(1 - 0.5 \frac{p_{sd}}{p_f} \right) \quad (7.74)$$

where p_{sd} is design lateral pressure and p_f is the lateral pressure giving yield in outer-fibre at support.

$$p_f = \frac{12W}{l^2 \cdot s} \frac{f_y}{\gamma_M} \quad (7.75)$$

W = the smaller of W_{ep} and W_{es}

l = span length

In case of varying lateral pressure, p_{sd} in eq. (7.74) should be taken as the minimum of the value in the adjoining spans.

For simple supported stiffener $l_k = 1.0 \cdot l$.

7.8 Check for shear force

The stiffener should in all sections satisfy:

$$V_{Sd} \leq V_{Rd} = A_{net} \cdot \frac{f_y}{\gamma_M \sqrt{3}} \quad (7.76)$$

where:

V_{Sd} = design shear force

V_{Rd} = design shear resistance

A_{net} = net shear area (shear area minus cut outs)

If $V_{Sd} > 0.5 V_{Rd}$ then the stiffener section modulus and effective area need to be reduced to account for the interaction of the shear with the moment and axial force in the stiffener.

8 Buckling of girders

8.1 General

The check for girders is similar to the check for stiffeners of stiffened plates in equations (7.50) to (7.57) or (7.59) to (7.64) for continuous or sniped girders, respectively. Forces shall be calculated according to sec. 8.2 and cross section properties according to 8.4. Girder resistance should be found from sec. 8.3. Torsional buckling of girders may be assessed according to sec. 8.5.

In the equations (7.50) to (7.57) or (7.59) to (7.62) $u = 0$ for girders.

Girders may be checked for shear forces similar to stiffeners see sec. 7.8.

8.2 Girder forces

The axial force should be taken as:

$$N_{y,Sd} = \sigma_{y,Sd}(lt + A_G) \quad (8.1)$$

The lateral line load should be taken as:

$$q_{Sd} = (p_{Sd} + p_0)l \quad (8.2)$$

where

p_{Sd} = design lateral pressure

p_0 = equivalent lateral pressure

A_G = cross sectional area of girder

The calculation of the additional equivalent lateral pressure due to longitudinal compression stresses and shear shall be calculated as follows:

For compression in the x-direction:

$$p_0 = \frac{0.4 \left(t + \frac{A_s}{s} \right) f_y \left(\frac{L_G}{l} \right)^2 (\sigma_{x,Sd} + C\tau_{Sd})}{h_{wG} \left(1 - \frac{s}{L_G} \right)} \quad (8.3)$$

But not less than $0.02 \frac{t + \frac{A_s}{s}}{l} (\sigma_{x,Sd} + C\tau_{Sd})$

where

$$C = Q \left(7 - 5 \left(\frac{s}{l} \right)^2 \right) \left(\frac{\tau_{Sd} - \tau_{crG}}{\tau_{crI}} \right)^2 \quad \text{for } \tau_{Sd} > \tau_{crG} \quad (8.4)$$

$$C = 0 \quad \text{for } \tau_{Sd} \leq \tau_{crG} \quad (8.5)$$

$$Q = \bar{\lambda}_G - 0.2, \text{ but not less than } 0 \text{ and not greater than } 1.0$$

$$\bar{\lambda}_G = \sqrt{\frac{f_y}{f_{EG}}} \quad f_{EG} \text{ is given in eq. (8.11)}$$

τ_{crG} = critical shear stress of panel with girders removed, calculated from eq.(8.6) with $\bar{\lambda}_\tau$ calculated using

$\tau_{ce} = \tau_{ceg}$. If the stiffener is not continuous through the girder $\tau_{crG} = 0$.

τ_{crI} = critical shear stress of panel between girders calculated from eq. (8.6) with $\bar{\lambda}_\tau$ calculated using $\tau_{ce} = \tau_{ceI}$

$$\tau_{cr} = 0.6f_y, \text{ for } \bar{\lambda}_\tau \leq 1 \quad (8.6)$$

$$= \frac{0.6}{\bar{\lambda}_\tau^2} f_y, \text{ for } \bar{\lambda}_\tau > 1$$

$$\bar{\lambda}_\tau = \sqrt{\frac{0.6f_y}{\tau_{ce}}}$$

with

$$\tau_{ceg} = \frac{\tau_{ceI} \cdot l^2}{L_P^2}$$

$$\tau_{ceI} = \frac{18E}{t l^2} \left(\frac{t I_s}{s} \right)^{0.75}$$

L_P = length of panel

h_{wG} = web height of girder

A_s = cross sectional area of stiffener

L_G = girder span

s = stiffener spacing

I_s = moment of inertia of stiffener with full plate width

For linear variation of $\sigma_{x,Sd}$, the maximum value within $0.25L_G$ to each side of the midpoint of the span may be used.

τ_{Sd} should correspond to the average shear flow over the panel.

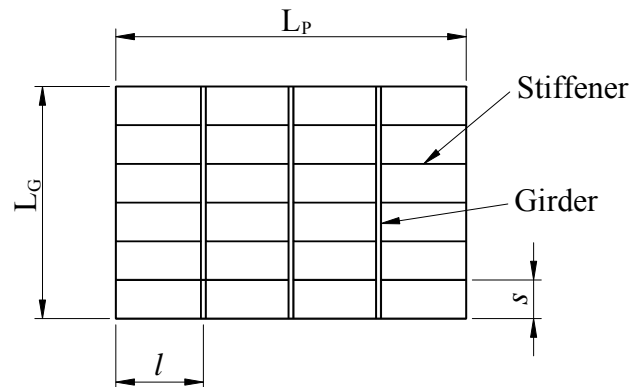

Figure 8-1 Panel geometry definitions

For tension in the x-direction:

$$p_0 = \frac{0.4 \left(t + \frac{A_s}{s} \right) f_y \left(\frac{L_G}{l} \right)^2 C_{\tau_{sd}}}{h_{wG} \left(1 - \frac{s}{L_G} \right) E} \quad (8.7)$$

8.3 Resistance parameters for girders

The resistance of girders may be determined by the interaction formulas in sec. 7.7 using the following resistance

$$N_{rd} = (A_G + l_e t) \frac{f_y}{\gamma_M} \quad (8.8)$$

$$N_{ks,Rd} = (A_G + l_e t) \frac{f_k}{\gamma_M} \quad (8.9)$$

where

f_k is calculated from sec. 7.5 using μ according to eq. (7.26).

$$N_{kp,Rd} = (A_G + l_e t) \frac{f_k}{\gamma_M} \quad (8.10)$$

where:

f_k is calculated from sec. 7.5 using μ according to eq. (7.25) using:

$f_r = f_y$ for check at plate side

$f_r = f_{TG}$ for check at girder flange side

$$f_{EG} = \pi^2 E \left(\frac{i_{Ge}}{L_{Gk}} \right)^2 \quad (8.11)$$

L_{Gk} = buckling length of girder equal L_G unless further evaluations are made

f_{TG} may be obtained from eq. (8.27)

A_G = cross sectional area of girder

l_e = effective width of girder plate, see sec. 8.4.

$$M_{s1,Rd} = W_{eG} \frac{f_r}{\gamma_M} \quad (8.12)$$

with f_r calculated using $l_t = 0.4 L_G$ or distance between lateral support if this is less.

$$M_{s2,Rd} = W_{eG} \frac{f_r}{\gamma_M} \quad (8.13)$$

with f_r calculated using $l_t = 0.8 L_G$ or distance between lateral support if this is less.

$$M_{st,Rd} = W_{eG} \frac{f_y}{\gamma_M} \quad (8.14)$$

$$M_{p,Rd} = W_{ep} \frac{f_y}{\gamma_M} \quad (8.15)$$

$W_{ep} = \frac{I_e}{Z_p}$, effective elastic section modulus on plate side, see Figure 7-3

$W_{eG} = \frac{I_e}{Z_t}$, effective elastic section modulus on girder flange side, see Figure 7-3

$$N_E = \frac{\pi^2 E A_{Ge}}{\left(\frac{L_{Gk}}{i_{Ge}} \right)^2} \quad (8.16)$$

where

$$i_{Ge} = \sqrt{\frac{I_{Ge}}{A_{Ge}}} \quad (8.17)$$

8.4 Effective widths of girders

8.4.1 General

The effective width for the plate of the girder is taken equal to:

$$\frac{l_e}{l} = C_{xG} \cdot C_{yG} \cdot C_{\tau G} \quad (8.18)$$

For the determination of the effective width the designer is given two options denoted method 1 and method 2. These methods are described in sec. 8.4.2 and 8.4.3 respectively:

8.4.2 Method 1

Calculation of the girder by assuming that the stiffened plate is effective against transverse compression (σ_y) stresses. See also Commentary Chapter 10 and sec. 7.1.

In this method the effective width may be calculated as:

$$C_{xG} = \sqrt{1 - \left(\frac{\sigma_{x,Sd}}{f_{kx}} \right)^2} \quad (8.19)$$

where:

$$f_{kx} = C_{xs} f_y \quad (8.20)$$

C_{xs} is found from eq. (7.14).

If the σ_y stress in the girder is in tension due to the combined girder axial force and bending moment over the total span of the girder C_{yG} may be taken as:

$$C_{yG} = 1.0 \quad (8.21)$$

If the σ_y stress in the plate is partly or complete in compression C_{yG} may be found from eq. (7.16).

$$C_{xG} = \sqrt{1 - 3 \left(\frac{\tau_{Sd}}{f_y} \right)^2} \quad (8.22)$$

l_e should not be taken larger than 0.3 L_G for continuous girders and 0.4 L_G for simple supported girders when calculating section modules W_{ep} and W_{eG} .

8.4.3 Method 2

Calculation of the girder by assuming that the stiffened plate is not effective against transverse compression stresses (σ_y). See also Commentary Chapter 10 and Sec. 7.1.

In this case the plate and stiffener can be checked with σ_y stresses equal to zero.

In method 2 the effective width for the girder should be calculated as if the stiffener was removed.

then:

$$C_{xG} = \sqrt{1 - \left(\frac{\sigma_{x,Sd}}{f_y} \right)^2} \quad (8.23)$$

where $\sigma_{x,Sd}$ is based on total plate and stiffener area in x-direction.

$$C_{yG} = \begin{cases} \frac{\bar{\lambda}_G - 0.22}{\bar{\lambda}_G^2} & \text{if } \bar{\lambda}_G > 0.673 \\ = 1.0, & \text{if } \bar{\lambda}_G \leq 0.673 \end{cases} \quad (8.24)$$

where

$$\bar{\lambda}_G = 0.525 \frac{l}{t} \sqrt{\frac{f_y}{E}} \quad (8.25)$$

$$C_{\tau G} = \sqrt{1 - 3 \left(\frac{\tau_{Sd}}{f_y} \right)^2} \quad (8.26)$$

8.5 Torsional buckling of girders

The torsional buckling strength of girders may be determined as:

$$f_{TG} = f_y \quad \text{if } \bar{\lambda}_{TG} \leq 0.6 \quad (8.27)$$

$$f_{TG} = f_y \cdot \left(\frac{1 + \mu + \bar{\lambda}_{TG}^2 - \sqrt{(1 + \mu + \bar{\lambda}_{TG}^2)^2 - 4\bar{\lambda}_{TG}^2}}{2\bar{\lambda}_{TG}^2} \right) \quad \text{if } \bar{\lambda}_{TG} > 0.6$$

$$\bar{\lambda}_{TG} = \sqrt{\frac{f_y}{f_{ETG}}} \quad (8.28)$$

$$\mu = 0.35(\bar{\lambda}_{TG} - 0.6) \quad (8.29)$$

where

$$f_{ETG} = \frac{\pi^2 E I_z}{\left(A_f + \frac{A_w}{3} \right) L_{GT}^2} \quad (8.30)$$

L_{GT} = distance between lateral supports

A_f, A_w = cross sectional area of flange and web of girder

I_z = moment of inertia of girder (exclusive of plate flange) about the neutral axis perpendicular to the plate

Torsional buckling need not be considered if tripping brackets are provided so that the laterally unsupported length L_{GT} , does not exceed the value L_{GT0} defined by:

$$\frac{L_{GT0}}{b} = C \sqrt{\frac{E A_f}{f_y \left(A_f + \frac{A_w}{3} \right)}} \quad (8.31)$$

where

b = flange width

C = 0.55 for symmetric flanges

1.10 for one sided flanges

Tripping brackets are to be designed for a lateral force P_{Sd} , which may be taken equal to (see Figure 8-2):

$$P_{Sd} = 0.02 \sigma_{y,Sd} \left(A_f + \frac{A_w}{3} \right) \quad (8.32)$$

$\sigma_{y,Sd}$ = compressive stress in the free flange

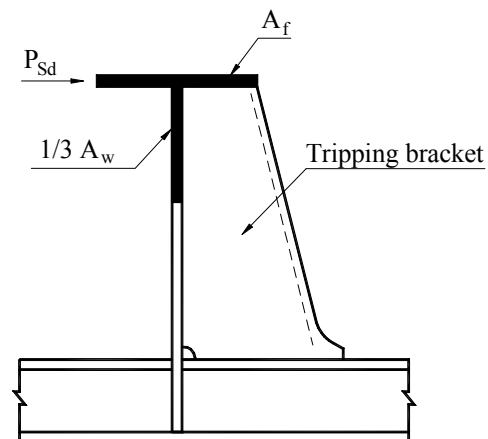

Figure 8-2 Definitions for tripping brackets

9 Local buckling of stiffeners, girders and brackets

9.1 Local buckling of stiffeners and girders

9.1.1 General

The methodology given in Chapter 7 and Chapter 8 is only valid for webs and flanges that satisfy the the following requirements or fulfils requirements to cross section type III defined in Appendix A of DNV-OS-C101.

Flange outstand for T or L stiffeners or girders should satisfy:

$$c \leq 14 t_f \varepsilon \quad \text{for welded sections} \quad (9.1)$$

$$c \leq 15 t_f \varepsilon \quad \text{for rolled sections}$$

For definition of c see Figure 7-3 .

Web of stiffeners and girders should satisfy:

$$h_w \leq 42 t_w \varepsilon \quad (9.2)$$

$$\varepsilon = \sqrt{\frac{235}{f_y}}$$

In lieu of more refined analysis such as in Chapter 7, web stiffeners should satisfy the requirements given in sec. 9.1.2 and sec. 9.1.3.

9.1.2 Transverse web stiffeners:

$$I_s > 0.3 l_t s^2 t_w \left(2.5 \frac{l_t}{s} - 2 \frac{s}{l_t} \right) \frac{f_y}{E} \quad (9.3)$$

I_s = moment of inertia of web stiffener with full web plate flange s

l_t = length of transverse web stiffener

s = distance between transverse web stiffeners

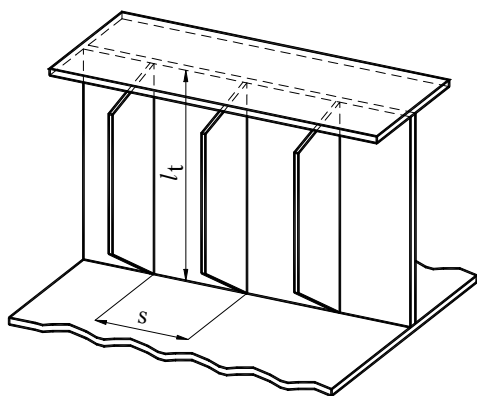

Figure 9-1 Definitions for transverse web stiffeners

9.1.3 Longitudinal web stiffener:

$$I_s > 0.25 l_l^2 (A_s + s t_w) \frac{f_y}{E} \quad (9.4)$$

I_s = moment of inertia of web stiffener with full web plate flange s .

A_s = cross sectional area of web stiffener exclusive web plating.

l_l = length of longitudinal web stiffener

s = distance between longitudinal web stiffeners

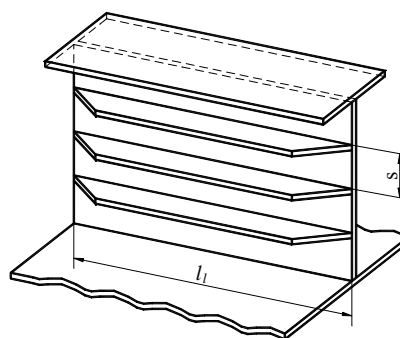

Figure 9-2 Definitions for longitudinal web stiffeners

9.2 Buckling of brackets

Brackets should be stiffened in such a way that:

$$d_0 \leq 0.7 t_b \sqrt{\frac{E}{f_y}} \quad (9.5)$$

$$d_1 \leq 1.65 t_b \sqrt{\frac{E}{f_y}} \quad (9.6)$$

$$d_2 \leq 1.35 t_b \sqrt{\frac{E}{f_y}} \quad (9.7)$$

t_b = plate thickness of bracket.

Stiffeners as required in eq. (9.6) or eq. (9.7) may be designed in accordance with Chapter 7. See Figure 9-3.

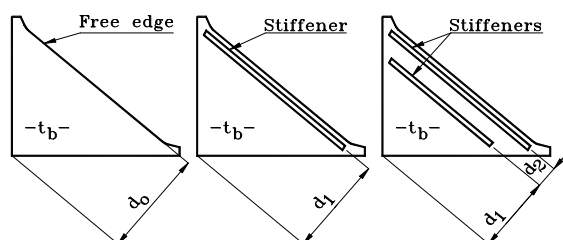

Figure 9-3 Definitions for brackets

10 Commentary

Commentary to 3.4 Tolerance requirements

An important factor for the buckling strength is the imperfections that are permitted. As a basis the formulas are developed on the basis that the imperfections are similar to what is allowed in the DNV-OS-C401 Fabrication and Testing of Offshore Structures. There are differences in this standard and what is allowed in DNV Classification Rules for Ships and IACS “Shipbuilding and Repair Quality Standard-Part A. However, the formulas is seen as being relevant for both typical ship with normal good practice and offshore structures even if an nonlinear FEM analysis of the panel including the worst combination of allowable imperfections may yield less resistance than obtain from the RP formulas. The reason why this is seen as acceptable is the following:

- The resistance of stiffened plate structures is dependent on imperfections in several elements. Both the imperfection size and pattern for both the plate and stiffener are important and it is less probable that they have their maximum at the same time.
- The resistance is dependent on more than one element. It is less probable that all elements have their most detrimental imperfection pattern and size at the same time.
- The importance of the imperfection is largest for small slenderness plate and stiffeners while the likelihood of deviations are largest for large slenderness plates.
- There are several supportive effects in a real stiffened plate structure that are disregarded in the resistance formulations that will in many cases mean a capacity reserve that is larger than the effect from imperfections.

For structures where these elements are less valid it may be necessary to evaluate the effect of imperfections separately. An example may be a short stocky sniped stiffener constructed according to ship rules fabrication tolerances and where redistribution of stresses are not possible. Ship rules tolerances are given with a tolerances that are independent of the member length. This will imply that the tolerances are larger than the basis for this Recommended Practise and the capacity of short members may be over-predicted.

Commentary to 4.4 Determination of buckling resistance based upon linear elastic buckling stress

Linear elastic buckling stress found from literature or by FEM eigenvalue analyses may be used as basis for determination of buckling resistance. In order to account for material non-linearity, residual stresses and imperfection a suitable buckling curve may be used by calculating the reduced slenderness parameter defined as:

$$\bar{\lambda}_p = \sqrt{\frac{f_y}{f_{cr}}}$$

where f_{cr} is linearised buckling stress.

The linearised buckling stress should be carefully selected to be maximum compressive stress in the analysis. From the reduced slenderness a buckling resistance may be determined by using an appropriate buckling curve. Normally a column buckling curve as defined in eq. (7.21) and eq. (7.22) can be used unless it is evident that a plate buckling curve as defined in eq. (6.2) and eq. (6.6) or a shear buckling curve as in eq. (6.17) can be used.

In case of interaction effects e.g. between local and global buckling the interaction effects can be conservatively accounted for by calculated a combined linearised buckling stress according to the following formula:

$$\frac{1}{f_{crcomb}} = \frac{1}{f_{crglobal}} + \frac{1}{f_{crllocal}}$$

Commentary to 6 Buckling of unstiffened plates

Slender plates designed according to the effective width formula utilise the plates in the post critical range. This means that higher plate stresses than the buckling stress according to linear theory or the so-called critical buckling stress are allowed. Very slender plates, i.e. span to thickness ratio greater than 120, may need to be checked for serviceability limit states or fatigue limit states. Examples of failure modes in the serviceability limit states are reduced aesthetic appearance due to out of plane distortions or snap through if the plate is suddenly changing its out of plane deformation pattern. As the main source for the distortions will be due to welding during fabrication, the most effective way to prevent these phenomena is to limit the slenderness of the plate. The likelihood of fatigue cracking at the weld along the edges of the plate may increase for very slender plates if the in plane loading is dynamic. This stems from bending stresses in the plate created by out of plane deflection in a deflected plate with in plane loading. For plates with slenderness less than 120, ordinary fatigue checks where out of plane deflections of plate are disregarded will be sufficient.

Commentary to 7 Buckling of stiffened plates

For wide flanges the stresses in the longitudinal direction will vary due to shear deformations, (shear lag). For buckling check of flanges with longitudinal stiffeners shear lag effects may be neglected as long as the flange width is less than 0.2 L to each side of the web (bulkhead). L being length between points of counterflexure.

Commentary to 7.2 Forces in the idealised stiffened plate

With tension field action is understood the load carrying action in slender webs beyond the elastic buckling load.

Commentary to 7.4 Resistance of plate between stiffeners

If secondary stiffeners are used to stabilise the plate field between ordinary stiffeners the secondary stiffeners need to be checked as a plate stiffener and the ordinary stiffeners as girders according to sec. 7.5 and Chapter 8, respectively.

Commentary to 7.7 Interaction equations for axial compression and lateral pressure

The equations (7.50) and (7.51) may be seen as interaction formulas for the stiffener and plate side respectively for a section at the support. Equations (7.52) and (7.53) are likewise interaction checks at the mid-span of the stiffener. See also Figure 10-1.

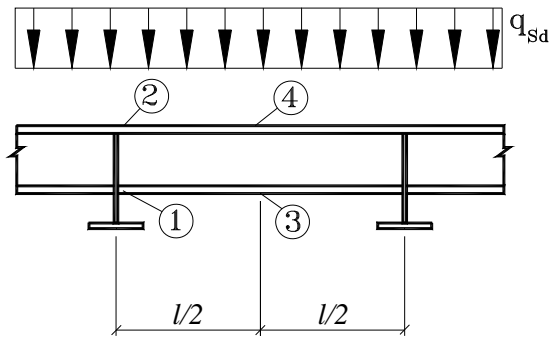

Figure 10-1 Check points for interaction equations

With the lateral load on the stiffener side, the stresses change sign and the equations (7.54) to (7.57) shall be used. The sections to be checked remain the same.

The eccentricity z^* is introduced in the equations to find the maximum resistance of the stiffened panel. In the ultimate limit state a continuous stiffened panel will carry the load in the axis giving the maximum load. For calculation of the forces and moments in the total structure, of which the stiffened panel is a part, the working point for the stiffened panel should correspond to the assumed value of z^* . In most cases the influence of variations in z^* on global forces and moments will be negligible. See also Figure 10-2.

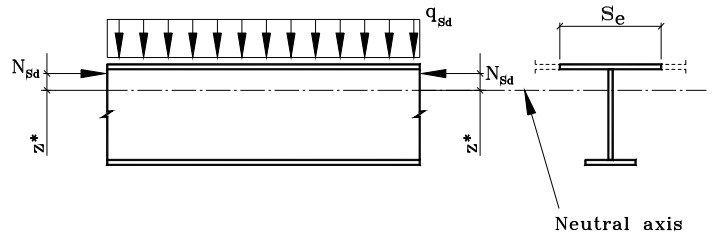

Figure 10-2 Definition of z^* . Positive value shown

The maximum capacity will be found for the value of z^* when the largest utilisation ratio found for the four equations is at its minimum. See Figure 10-3.

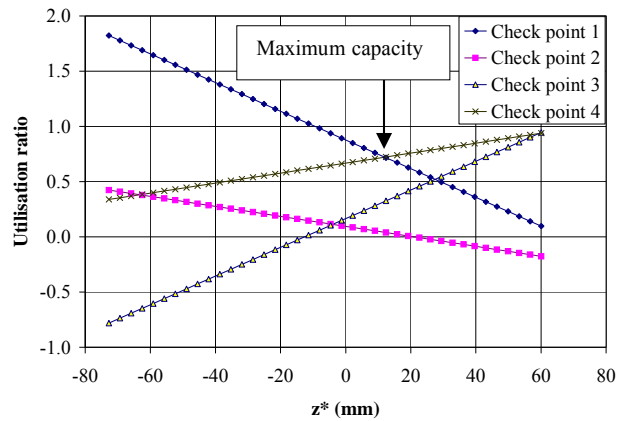

Figure 10-3 Utilisation ratios for the four interaction equations with varying z^*

Commentary to 8 Buckling of girders

When a stiffened panel supported by girders is subjected to lateral loads the moments from this load should be included in the check of the girder. If the girder is checked according to method 1, the stiffener and plate should also be checked for the σ_y stresses imposed by the bending of the girder. In method 2, the σ_y stresses imposed by the bending of the girder can be neglected when checking plate and stiffener.

Part 2.

Buckling Strength of Plated Structures - PULS Buckling Code

1 Introduction

1.1 General

1.1.1 This part describes an accepted computerised semi-analytical model for ultimate and buckling strength assessment of thin-walled unstiffened or stiffened flat plates. The code has the name PULS as a shortcut for Panel Ultimate Limit State.

1.1.2 The PULS code assess the buckling strength of different types of elements classified according to their structural action and position in large plated constructions, e.g. in ship hulls, offshore platforms etc., Figure 1.

1.1.3 The code can be used for both steel and aluminium material. Special criteria are introduced for aluminium alloys with respect to Heat affected zone effects (HAZ).

1.1.4 Application to other metallic materials than steel and aluminium is possible. Special care is needed with respect to welding effects, heat affected zone effects etc.

1.1.5 The PULS code is programmed in a Visual basic (VB) environment. Two separate user interfaces are available using the same input/output file format, see Sec. 1.6.

1.1.6 The PULS VB program will be revised and updated with respect to new element types, improved solutions, new features etc. whenever appropriate. The latest official program version with corresponding documentation is available by contacting the authorised unit within DNV.

1.1.7 The PULS code is implemented into other user interface applications and as postprocessors in different DNV software.

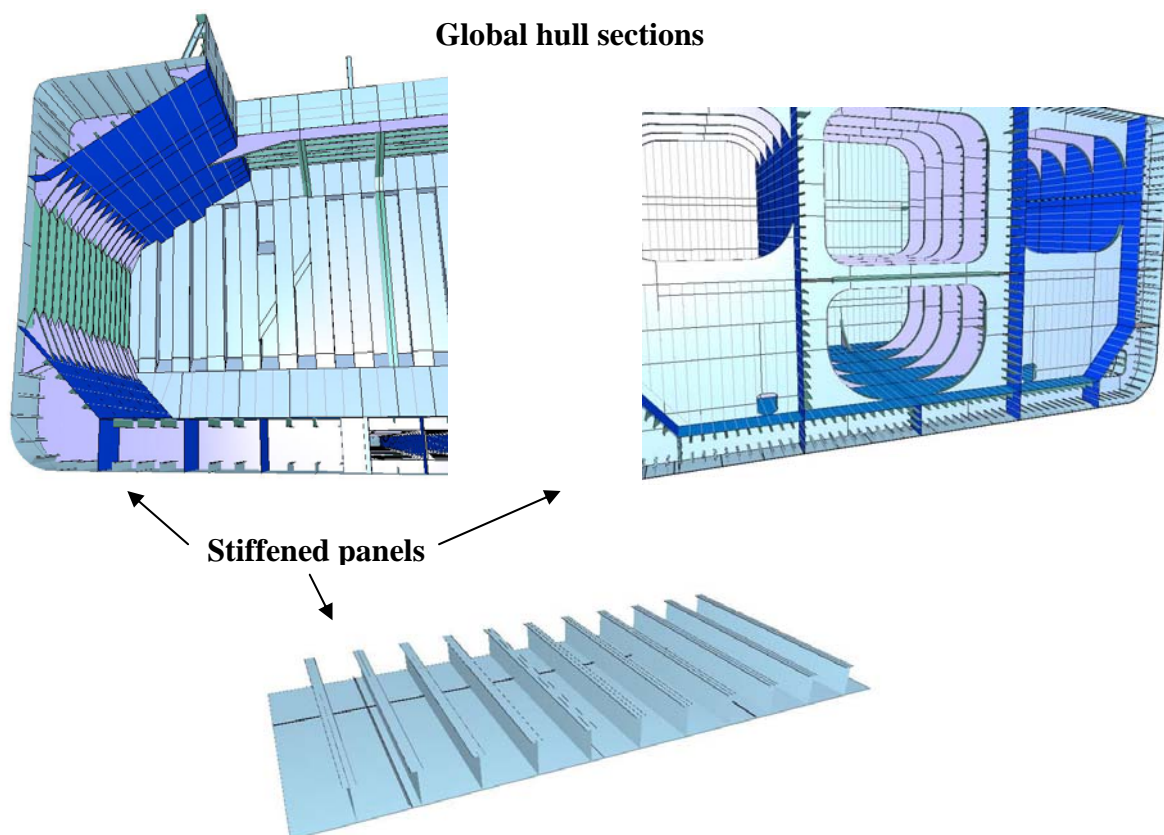

Figure 1 Ship hulls with stiffened panels as main building block

1.2 Purpose

1.2.1 The present computerised buckling code is introduced as an alternative to the more standard buckling code format given in the first part of the present document. The purpose is to assess the ultimate and buckling strength limits with greater consistency than available with more empirical curve fitting approaches.

1.2.2 The code also facilitate reduced orthotropic stiffness parameters of elastically deformed/buckled plates. These properties are meant for application on large plated structures analysed using linear finite elements programs and coarse meshing, typically FE plate and shell models with one element between stiffeners. The goal with such applications is to improve the assessment of the nominal stress flow in ship hulls etc. accepting and accounting for local elastic plate buckling between stiffeners. The option of anisotropic/orthotropic material models in standard FE programs can be used. Details of such applications are not described here.

1.3 Theoretical background

1.3.1 The PULS models are based on a recognized non-linear thin-walled plate theory according to Marguerre and von Karman see e.g. Ref. [1], [2]. A harmonic Rayleigh-Ritz discretization of deflections is used together with energy principles for establishing the non-linear elastic equilibrium equations. The equilibrium equations are solved using incremental numerical procedures.

1.3.2 For stiffened panels the models are based on an orthotropic version of Marguerre's plate theory in which the stiffeners are smeared out over the plate surface. The elastic local buckling, postbuckling and imperfection effects of each component plate in the cross-section are lumped into a set of reduced orthotropic stiffness coefficients. These reduced orthotropic coefficients are used for assessing the upper bound global elastic buckling limit.

1.3.3 In non-linear elastic buckling theory the internal stress distribution is split in two categories i.e. the direct external applied stresses and a second order stress field due to the combined effect of buckling and geometrical imperfections. The latter stress field is due to the non-linear geometrical effect. These stress categories add together forming a redistributed stress field across the panel.

1.3.4 In the Puls code the redistributed stress field is used for identifying the critical positions ("hard corners") where material yielding starts. The values of the external loads, at which the redistributed membrane stresses reaches the yield condition, are used as indicators for the ULS strength (limit state formulations). For stiffened panels the largest redistributed stresses will typically be along supported edges or along plate-stiffener junction lines.

1.4 Code principles

1.4.1 The ultimate load bearing capacity of plates will depend on whether the considered plate and/or stiffened panel constitute an integrated part of a bottom, deck, ship side or bulkhead construction or whether they are a part of a girder web with free membrane boundary conditions. Integrated thin plates in a ship deck, bottom or ship sides etc. can carry loads far beyond the ideal elastic buckling load (over critical strength), while plates with free membrane stress support has limited overcritical strength.

1.4.2 For integrated elements and extreme load design (ULS design), elastic buckling is accepted, i.e. large elastic displacements are accepted as long as the consequences are controlled and accounted for.

1.4.3 Ideal elastic buckling stresses (eigenvalues) are independent of the in-plane (membrane stiffness) support from neighbouring elements. They are useful as reference values and can be used as upper limits in case of functional considerations i.e. for load conditions and structural parts in which elastic buckling and thereby large elastic displacements are not acceptable (SLS philosophy). Ideal elastic buckling stresses is also acceptable as the upper limits for web girder design, stringer decks etc.

1.4.4 The yield stress to be used in a code strength prediction is to be the characteristic value as specified for each material type in the rules.

1.4.5 The PULS ULS capacity assessment is based on the redistributed stress distribution and local material yield criterion in highly stressed positions ("hard corners") along plate edges and stiffener plate junction lines. This will limit extensive damages and permanent sets.

1.4.6 There is no coupling between strength assessments of different element types, i.e. the strength evaluation of the stiffened panel is self-contained with no need for buckling check of the individual plate elements of which it is composed.

1.4.7 The PULS ultimate capacity values, using the default settings for imperfections, are consistent with the IACS Shipbuilding and Quality Repair Manual and DNV-OS-C401 fabrication standard.

1.4.8 Required safety margin against ULS element failure depends on type of construction, global redundancy, probability of loads and consequence of failure. Required safety margins are given in respective Ship rules and Offshore standards.

1.5 Safety formats

1.5.1 The PULS code calculates the usage factor η as a measure of the available safety margin. The usage factor represents the ratio between the applied combined loads and the corresponding ultimate strength values (ULS). It is a parameter used in DNV Ship Rule contexts.

1.5.2 For combined loads the usage factor is defined as the ratio between the radius vector to the applied load point in load space and the corresponding radius vector to the ULS collapse boundary, Figure 2.

The usage factor is defined as

$$\eta = L_0 / L_u$$

where the radius vectors L_0 and L_u in load space are defined as

$$L_0 = \sqrt{(\sigma_{10}^2 + \sigma_{20}^2 + \dots + \sigma_{i0}^2 + \dots + \sigma_{K0}^2)}$$

$$L_u = \sqrt{(\sigma_{1u}^2 + \sigma_{2u}^2 + \dots + \sigma_{iu}^2 + \dots + \sigma_{Ku}^2)}$$

K is the maximum number of simultaneously acting independent in-plane load components.

1.5.3 For a single load cases the definition of usage factor 1.5.2 becomes

$$\eta = \sigma_{i0} / \sigma_{iu} \quad i = \text{axial load, transverse load etc.}$$

1.5.4 The ULS acceptance criterion is

$$\eta < \eta_{\text{allow}}$$

η_{allow} ($=\eta_{\text{max}}$) is the acceptable usage factor specified in the rules. It will vary depending on the probability level of the loads, consequence of failure and global redundancy of the construction.

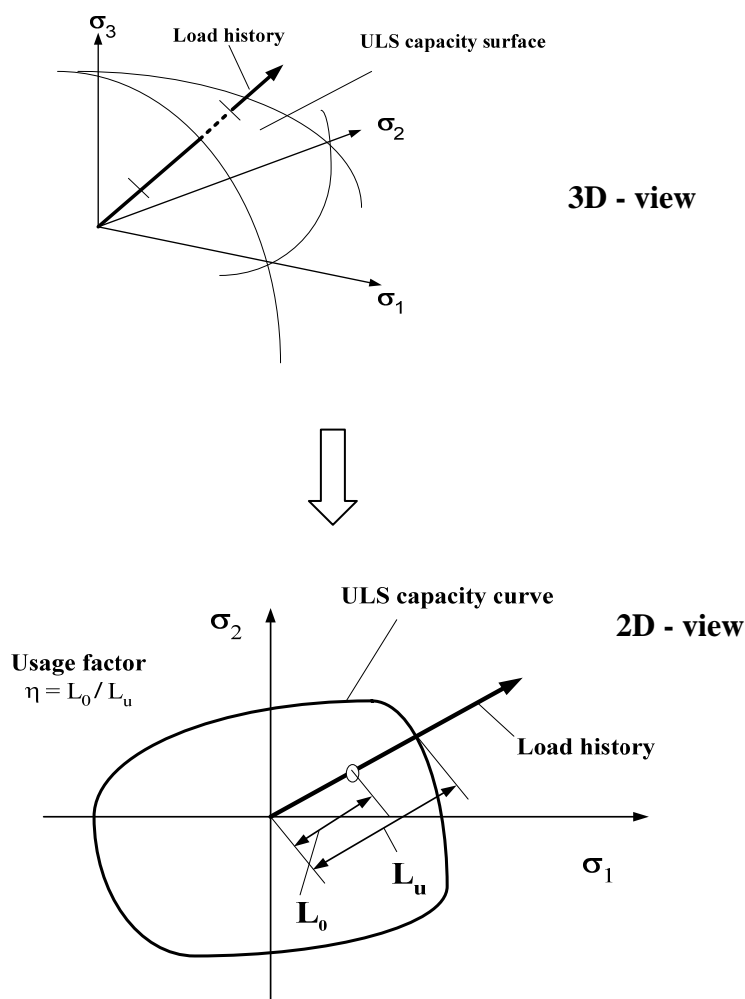

Figure 2 Definition of safety margin/usage factor; example for bi-axial loading on a plate

1.5.5 In the DNV Offshore Standards the LRFD format is used. This implies that the acceptance criterion is on the form

$$S_d < R_d$$

S_d is the load effect including relevant problem dependent load factors. R_d is the design resistance, which is related to the characteristic resistance as

$$R_d = R_k / \gamma_m$$

The factor γ_m is the material parameter given in the respective offshore standards.

1.5.6 The LRFD offshore strength format in the PULS terminology is

$$\eta < \eta_{\text{allow}} \quad \text{where} \quad \eta = \frac{S_d}{R_k} \quad \text{and} \quad \eta_{\text{allow}} = \frac{1}{\gamma_m}$$

The following definitions for S_d and R_k in case of combined loads apply:

Load effect $S_d \equiv L_0$ (design load effect inclusive load factors)

Characteristic resistance $R_k \equiv L_u$ (ultimate strength exclusive safety factors)

The ratio S_d / R_k is the same as the usage factor η . It gives a consistent measure of the safety margin. The material factor γ_m is the inverse of the acceptable usage factor η_{allow} .

1.5.7 The ratio $(\eta / \eta_{\text{allow}})$ can be used as a measure of the safety margin relative to the required strength margin, i.e.

$$\frac{\eta}{\eta_{\text{allow}}} < 1$$

1.5.8 The offshore WSD format in PULS terminology implies that $\eta < \eta_p$ where η_p is permissible usage factor given in the offshore standard DNV-OS-C201 and η is the actual usage factor as calculated by the PULS code.

1.6 PULS software features

1.6.1 The PULS code is supported by two separate stand-alone user interfaces applying the same input/output file format (pbp):

- Advanced Viewer (AV): Simple cell input of data with basic result presentation. More results available such as 3D graphics of buckling deflections, redistributed stresses, capacity curves for combined loads etc.
- Excel spread sheet: Simple data input and output line by line. A special option for systematic variation of main design parameters such as stiffener height etc. is available.

1.6.2 The PULS code is also available in a dll format (PulsComClasses) for implementation as a post-processor in linear FE codes or similar analyses tools.

1.6.3 The software features and basic theoretical background is found in Ref.[3]. More details, publications, papers etc. can be found on the DNV internet site www.dnv.com

1.7 References

- /1/ Washizu, K. (1975). “Variational methods in elasticity and plasticity”, Pergamon Press, Second Edition, Bath, Great Britain.
- /2/ Brush.D.O. and Almroth. B.O. “Buckling of Bars, Plates and Shells”, McGraw-Hill 1975
- /3/ NAUTICUS HULL, User Manual – PULS, July 2007, DNV Software.